



Front Bumper

FOR GM T1 HD Chevrolet/GMC

16060021AA - Chevrolet

16060022AA - GMC

NEW PRODUCT

Please visit www.aev-conversions.com to view the most current installation guide for this product.

This is a new product and we want to make sure that you receive the latest and most accurate information based on customer feedback, product revisions, and/or model year updates. We value customer feedback, so we encourage you to contact our Technical Support department if you have any suggestions on how to make the installation of this product easier or if you have any questions regarding the installation of this product. AEV's Technical Support can be reached by email at tech@aev-conversions.com or by giving us a call at (248)-926-0256.

INSTALLATIONGUIDE



PLEASE READ BEFORE YOU START

To guarantee a quality installation, we recommend reading these instructions thoroughly before beginning any work. These instructions assume a certain amount of mechanical ability and are not written nor intended for someone not familiar with auto repair.

INCLUDED PARTS	QTY	REQUIRED TOOLS
Front Bumper	1	Common Hand Tools
Air Baffle	1	Trim Removal Tools
Molding Sub Assembly	1	
Mounting Kit	1	

Recommended Accessories:

AEV-purchased components:

- Radiator Skid Plate PN 57060000AA
- Winch Mounting Kit PN 16060020AA

GM-purchased components:

- Chevrolet: Wheel Liner PN 85049656 (RH) and 85049655 (LH)
- GMC: Wheel Liner PN 85049658 (RH) and 85049657 (LH)
- RH Bumper Closeout PN 85049660
- LH Bumper Closeout PN 85049661
- 12pc M4.2 screws PN 11547421
- GM Accessories 12.5 ComeUp Winch Kit PN 19435527

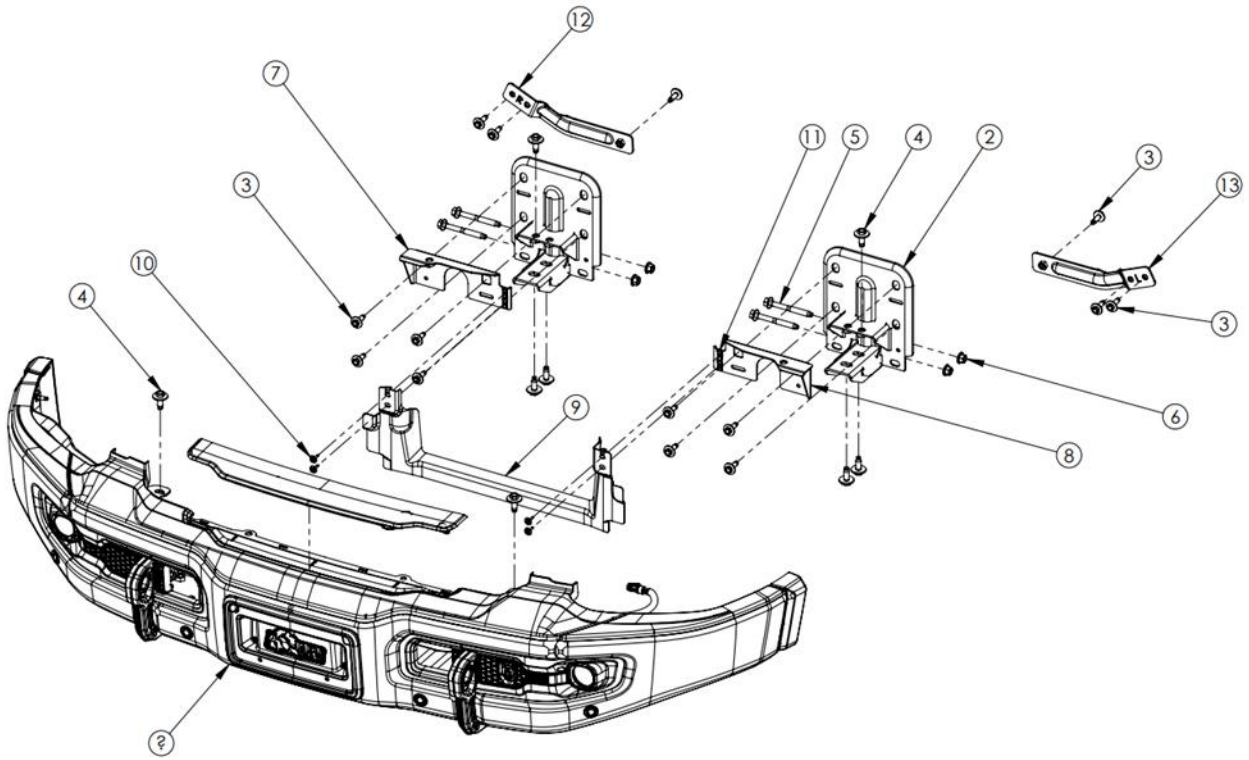

ITEM NO.	SERIAL #	PartNo	DESCRIPTION	QTY.
1	D040421	ATHB0021AK	SHIPPABLE ASSEMBLY, FRT BMPR, T1 HD CHEVY	1
2	D045982	ATHB0108AE	DIVING BOARD WELDMENT, FRT BMPR, T1 HD COMMON	2
3	D040432	11569600	M10 X 1.5 X 25 HEX BOLT AND WASHER ASM	14
4	D049945	11519536	M12 X 1.75 X 30 SCREW AND WASHER ASM	8
5	D040434	11609609	M12 X 1.75 X 105 HEX FLANGE BOLT	4
6	D040433	11549169	M12 X 1.75 FLANGE NUT PREVAILING TORQUE	4
7	D039672	ATHB0102AD	UPR FRAME HORN WELDMENT RH, FRT BMPR, T1 HD COMMON	1
8	D039690	ATHB0103AC	UPR FRAME HORN WELDMENT LH, FRT BMPR, T1 HD COMMON	1
9	D047241	ATHB1044AB	AIR BAFFLE, T1 HD COMMON FRT BMPR	1
10	D047895	11547421	M4.2 X 1.41 X 25 HEX BOLT ASM W/FLAT WASHER	4
11	D046810	11548673	M4.2 X 1.41 EXPANSION NUT (PANEL THICKNESS 1.4-5.0)	4
12	D049265	ATHB0110AD	PENCIL BRACE BRKT WELDMENT RH, T1 HD COMMON FRT BMPR	1
13	D049268	ATHB0111AD	PENCIL BRACE BRKT WELDMENT LH, T1 HD COMMON FRT BMPR	1
14	D047346	ATHB0011AA	MOLDING SUB ASSEMBLY, T1 HD COMMON FRT BMPR, TOP CAP CTR	1



1. Remove factory bumper: Refer to factory service manual, grill and fascia filler panels will also need to be removed to access upper bumper bolts. Note: Grill and fascia surround are held in by spring clips and will feel like they're being broken during removal. This is normal
 - a. Disconnect front camera and washer fluid hose if applicable prior to grill removal.
 - b. Disconnect bumper harness. (Passenger side)
 - c. Disconnect block heater. (Driver side)
 - d. Disconnect pencil braces from underneath, then 4 mounting bolts from above, then Remove bumper. Retain main M12 bumper mounting bolts.
 - e. Remove factory pencil braces and tow hooks from vehicle frame. Save hardware.



A.



B.



C.

2. Locate Left and Right pencil braces, install loosely in outboard body mount holes using provided M10x25 bolts. There is an L and R stamped in the brackets to identify them. The letter faces forward when installed.





3. Install Diving Board Weldment using factory Tow Hook Mounting Bolts , Leave loose. Start 2 front lower M10x25 bolts on bracket. Locate and install upper frame weldment (The LH and RH brackets are unique. The horizontal bumper mounting tab should be on the outboard side and the air baffle tab toward the inboard side). and start 2 upper M10x25 bolts. Visually align the upper bracket to center it around the vertical rib on the frame reinforcement bracket, then tighten all 4 front bolts; tighten lower bolts first, then uppers, followed by tow hook bolts. See torque table on last page for proper torque specifications.

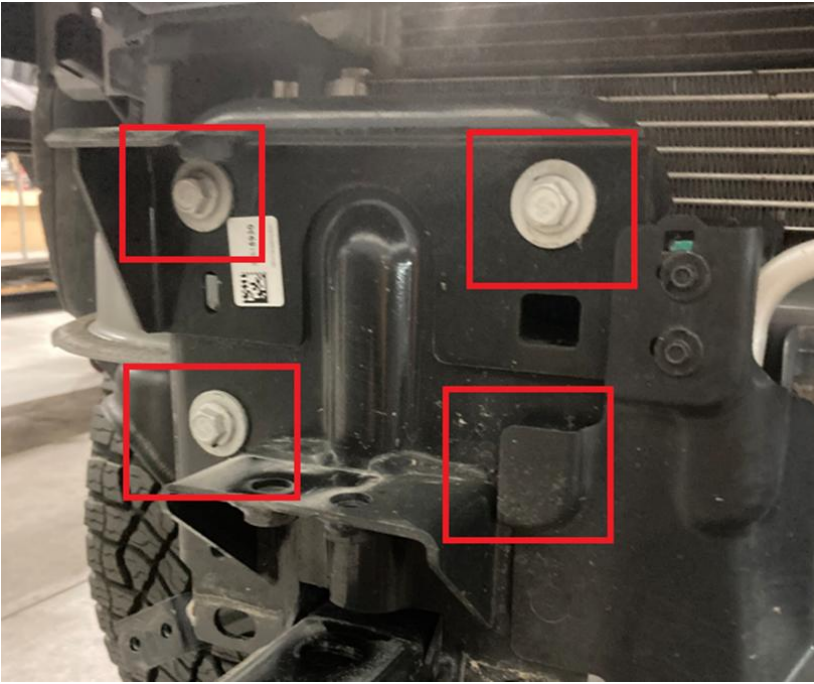

4. Install AEV-provided green push nuts into front of upper frame brackets, then install Air Baffle using M4.2x25 screws.





5. (Note: If installing winch, refer to winch kit instructions before installing bumper.)
Slide AEV Bumper into place resting on frame brackets. Ensure that lower winch flange is flush up against frame brackets.
- a. Install 4 upper bumper bolts using factory M12 bolts retained from bumper removal. Torque lower bolts first, then top bolts.



- b. From below, install 4 lower M12x30 washer head bumper bolts from AEV hardware kit.

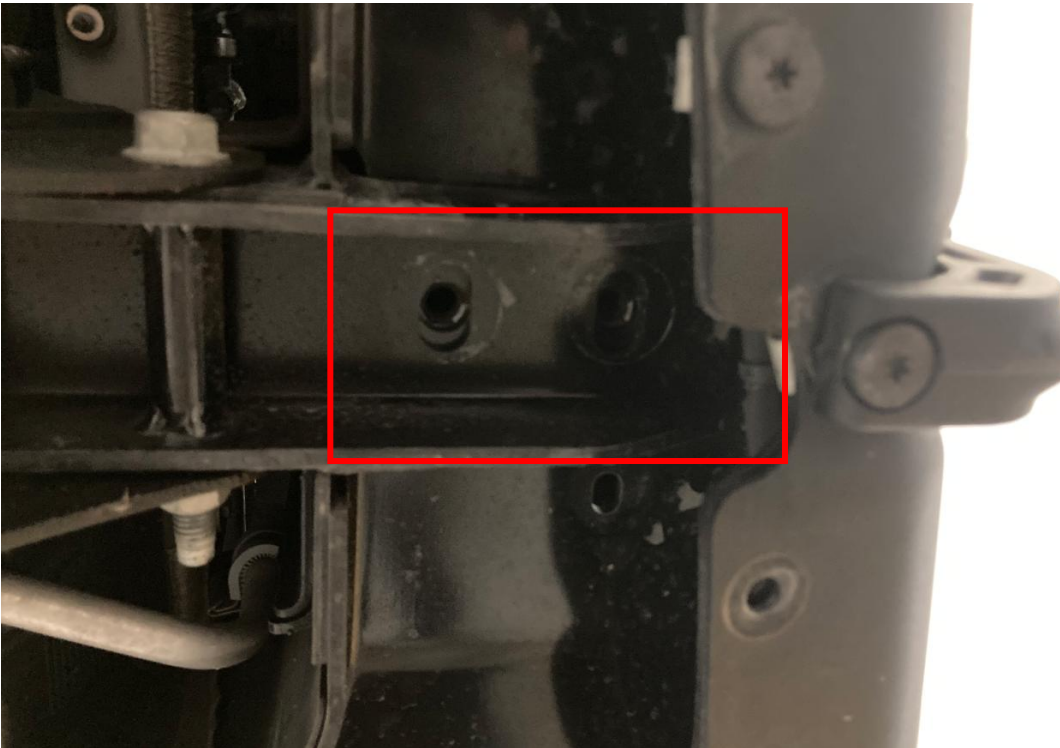



6. Install outer M10x25 pencil brace bolts, then torque both outer and inner bolts.



7. Install center bumper molding. (Note: Not used with winch kit)



8. Reinstall grill and fascia.
9. Install GM wheel well liner (See part numbers on page II) or factory wheel well liner can be trimmed per included template (Chevrolet AEV3049AA / GMC AEV30491AA) to accommodate AEV Bumper



10. AEV highly recommends installing GM corner closeout panels and AEV radiator skid plate. See part numbers on page II.



11. Install radiator skid plate available separately. Refer to skid plate instructions for process.

Torque Specifications:

Nominal Diameter (mm)	Minimum Bolt Material Grade GMW25	Standard Dynamic Torque (Nm)	(4) Standard Static Torque (Nm)
4.2	ISO2702	(1) D2.5+/-0.5NM	(3) 1NMMIN FDSNS
5	8.8	D4.7+/-0.9NM	3NMMIN FDSNS
6	8.8	D9+/-1.5NM	(2) S7.5-10.5NM
8	8.8	D22+/-3NM	S19-25NM
10	10.9	D58+/-9NM	S49-67NM
12	10.9	D100+/-15NM	S85-115NM
14	10.9	D160+/-25NM	S135-185NM
16	10.9	D240+/-35NM	S205-275NM