



TRANSFER CASE SKID

FOR GM LIGHT DUTY TRUCKS

PLEASE READ ENTIRELY BEFORE YOU START

To guarantee a quality installation, we recommend reading these instructions thoroughly before beginning any work. These instructions assume a certain amount of mechanical ability and are not written nor intended for someone not familiar with auto repair.

NOTE: If your vehicle does not contain the holes in the frame, the supplied riv-nuts must be utilized. Hold the skid plate into position and mark where the holes must go on the frame. Drill a 17/32" hole were marked and insert the correct size riv-nut. You may now proceed with the installation of your skid plate.



SKID PLATES

FOR GM LIGHT DUTY TRUCKS

ITEM NO.	PartNo	DESCRIPTION	QTY.
1	AT1P1200AA	FRONT IFS SKID, STAMPING, T1 LD SKID PLATES	1
2	AT1P0195AA	REAR DIFF SLIDER, WELDMENT, T1 LD SKID PLATES	1
3	AT1P0196AA	CLAMP, REAR DIFF, WELDMENT, T1 LD SKID PLATES	1
4	AT1P0142AA	WELDMENT, T1 LD SKID PLATES, TUBE FRT INR FUEL TANK	1
5	AT1P0147AA	WELDMENT, T1 LD SKID PLATES, TUBE RR INR FUEL TANK	1
6	AT1P1954AA	M8 U-BOLT, T1 LD SKID PLATES, REAR DIFF SLIDER	2
7	11588738	M10 X 1.5 X 25 HEX FLANGE BOLT	13
8	11611334	M8 X 1.25 X 30 HEX SCREW AND WASHER ASM	4
9	AT1P0013AA	ASSEMBLY, T1 LD SKID PLATES, T-CASE	1
10	11546377	M8 X 1.25 HEX FLANGE NUT	4
11	11548587	M8 X 1.25 U-NUT	6
12	11588724	M8 X 1.25 X 30 HEX FLANGE BOLT	2
13	11602140	M8 X 1.25 X 30 BOLT AND WASHER	4
14	11548585	M8 X 1.25 U-NUT	4
15	AT1P0141AA	WELDMENT, T1 LD SKID PLATES, RR INR FUEL TANK FLAG NUT	1
16	11546583	M10 X 1.5 U-NUT (PANEL THICKNESS RANGE 1.5-5.5)	11
17	AT1P0046AA	TUBE W/CAPTURED BOLT, RR OTR FUEL TANK, T1 LD SKID PLATES	1
18	11603624	M8 X 1.25 X 34.05 13mm HEX SOC, M-PT	4
19	AT1P0014AA	RADIATOR SKID, ASSEMBLY, T1 LD SKID PLATES	1
20	AT1P1400AA	FUEL TANK SKID, STAMPING, T1 LD SKID PLATES	1
21	11546366	M10 X 1.5 HEX FLANGE LOCK NUT	3



1. Install four M8 U-Nuts onto the transfer case skid (fig. 1).

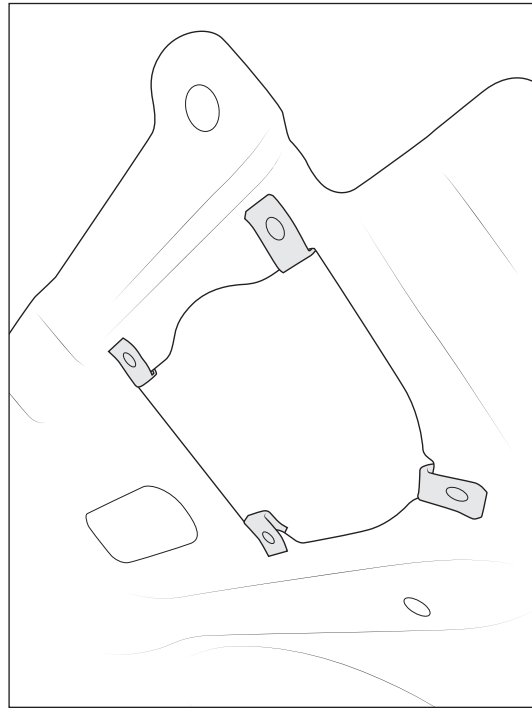

Figure 1

2. Install the Access Plate to the bottom of the skid using the four M8 bolt with captured washers (fig. 2).

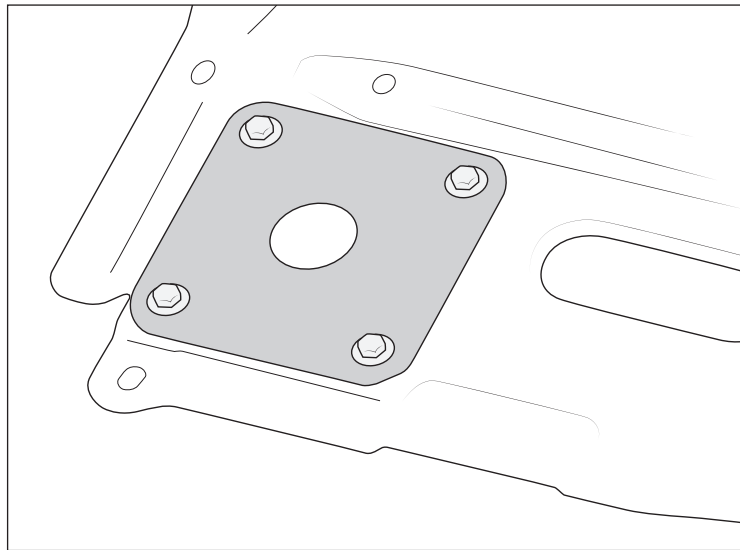

Figure 2



3. Install nine M10 U-nuts into the frame locations shown (fig. 3).

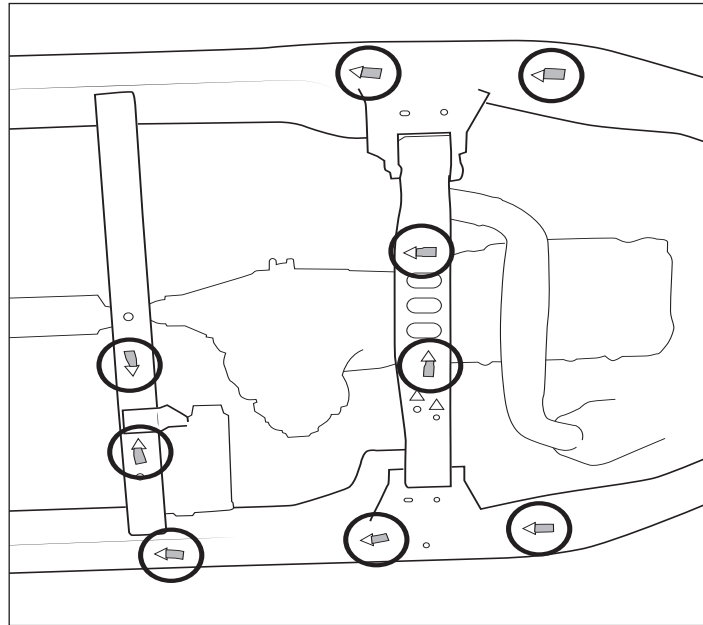

Figure 3

4. Use the supplied M10 bolts to install the skid plate onto the frame (fig. 4). Tighten to 40 ft-lbs

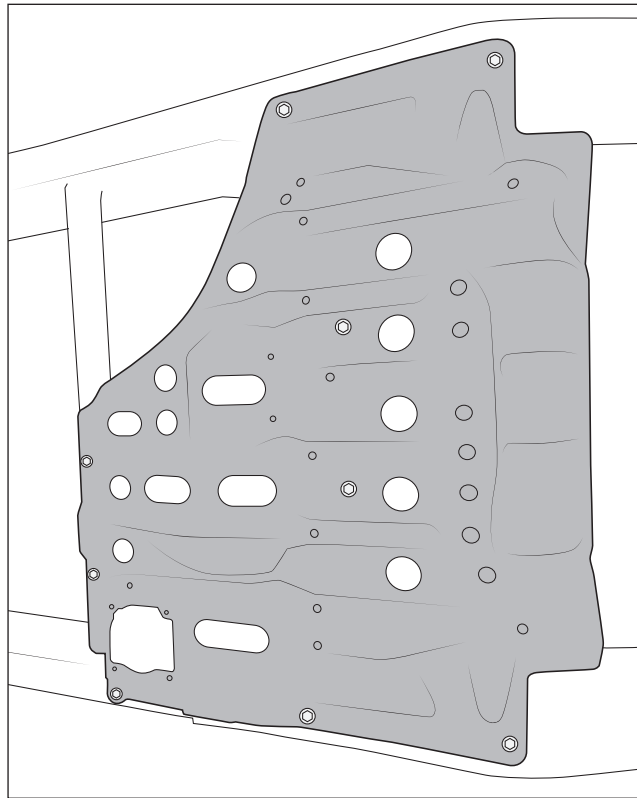

Figure 4