



# AEV Snorkel

For MY24+ JL / JT Wrangler + Gladiator

3.6L, 2.0L GAS ENGINES, 2.2L DIESEL (NON-US)

Please visit [www.aev-conversions.com](http://www.aev-conversions.com) to view the most current installation guide for this product.

This is a new product and we want to make sure that you receive the latest and most accurate information based on customer feedback, product revisions, and/or model year updates. We value customer feedback, so we encourage you to contact our Technical Support department if you have any suggestions on how to make the installation of this product easier or if you have any questions regarding the installation of this product. AEV's Technical Support can be reached by email at [tech@aev-conversions.com](mailto:tech@aev-conversions.com) or by giving us a call at (248)-926-0256.

**PLEASE READ BEFORE YOU START**

To guarantee a quality installation, we recommend reading these instructions thoroughly before beginning any work. These instructions assume a certain amount of mechanical ability and are not written nor intended for someone not familiar with auto repair.

INCLUDED PARTS	QTY	REQUIRED TOOLS
Snorkel Body Low Flare	1	1/16" Drill Bit
Snorkel Body High Flare	1	3/8" Step Bit
Hood Bezel	1	7/8" Hole Saw
Windshield Frame Bracket	1	Electric Cut-off Wheel or Air Saw Die Grinder
Fender Bracket	1	w/ Carbide Bit Flexible Straight Edge
Airbox Bracket	1	Center Punch
Air Ram	1	De-burring Tool
M6 Flat Washer	5	Touch-up Paint or Rust Inhibitor Rivet Tool
M6 X 20 Buttonhead Screw	5	Masking Tape
3/16" Rivet	4	Common Hand Tools
1/8" Long Rivet	2	
1/8" Short Rivet	5	
Snap Grip Clamp	1	



**BEFORE YOU BEGIN THE INSTALLATION, BE SURE TO CLEAN VEHICLE THOROUGHLY, INCLUDING THE ENGINE COMPARTMENT.**

## I. INSTALLING HOOD BEZEL

1. It is necessary to modify the factory hood to fit the snorkel. Cut out and place the trim template provided on the last page (also available at [aev-conversions.com](http://aev-conversions.com)) onto the right side of the hood (fig. 1). Place masking tape on the bottom 6" of the hood to protect the paint and provide a surface for marking the template outline. Measure 21.25" from rear edge of the hood to back edge of cutout (fig. 1).

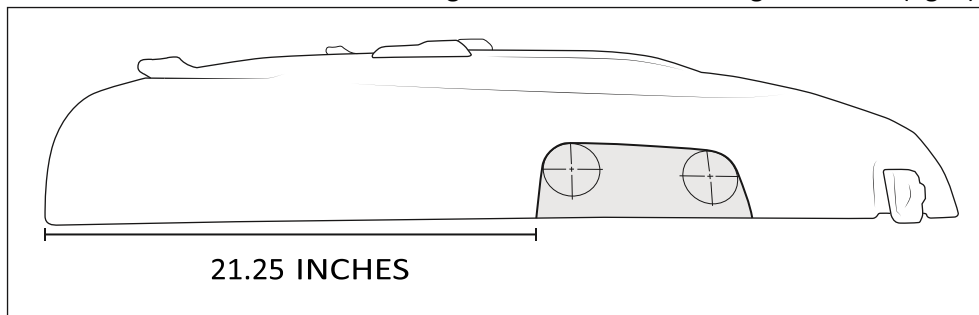

Figure 1

2. Align the dotted line of the trim template with the top tangent of the hood hem. Hold template in place and trace outline onto outer hood surface. After tracing, temporarily tape template in place on outside, open the hood, and wrap the inner portion onto inner panel. Hold the template tight to the hood contour and trace the outline, including onto the corner of the hood liner. Use heavy duty scissors to trim corner of hood liner about 1/4" past the marked line, then finish tracing the template onto the hood inner (fig. 2).

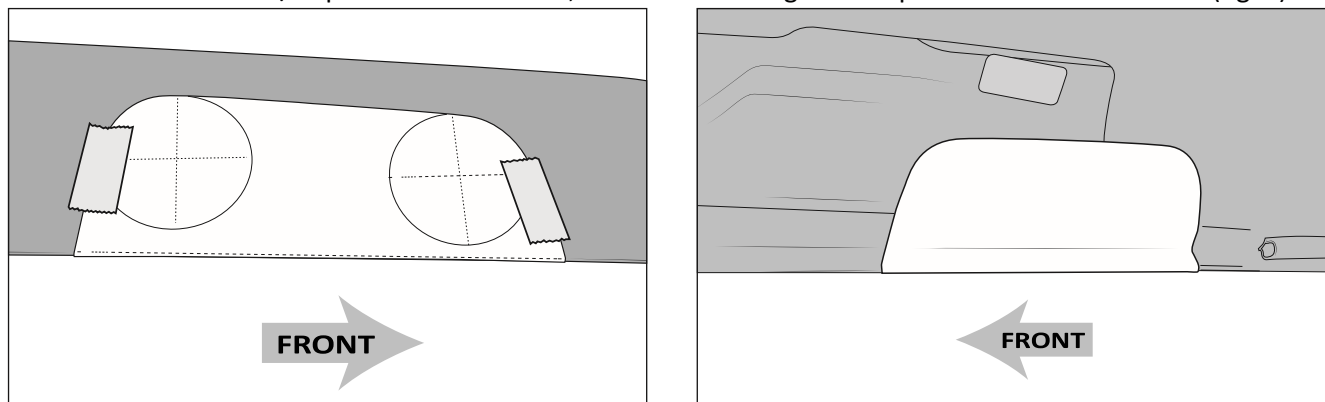

Figure 2: Outer Hood (left) Inner Hood (right)

3. Use a center punch to mark hole saw locations on template in the center of the 3" circles.
4. Temporarily prop the hood up 4-6" in order to cut the hood without damaging the fender or any under hood components. Cover and protect all glass, plastic, and painted parts from sparks and metal shavings.
5. Use a pilot drill to drill ONLY the outer layer of the hood first, then use the 3" hole saw to carefully cut through ONLY the outer layer (fig. 3). Cut gradually and carefully so that the hole saw doesn't grab and move off center

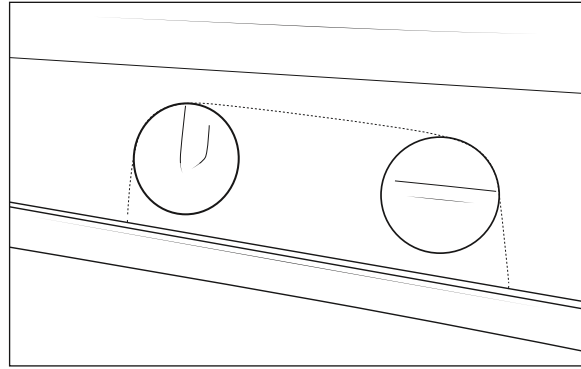

Figure 3

6. Using a cutoff wheel or reciprocating body saw, cut out the rest of the opening on the outer and inner panels. We recommend cutting the opening small and using a die grinder with sanding disc to gradually open up the opening until the bezel fits. Trim to the INSIDE of the lines marked with the template
7. Drill 1/8" holes square to outer surface in each dimple location on hood bezel.  
NOTE: If preferred, bezel can be adhered to hood with black RTV, silicone, etc instead of rivets. Adhesion promoter may be necessary depending on adhesive to be used. Drilling holes not necessary for adhesive mounting.
8. Hold bezel in place on hood and adjust to ensure there's enough material around front lower hole for rivet to stay away from the edge. Mark and drill 1/8" hole through all layers of hood in this location only. Hold hood bezel in place with one supplied 1/8" long rivet (do not pop yet). Hold bezel in position with one hand and mark the other holes with marker and/or center punch. Remove bezel and drill remaining holes. Front and rear bottom holes will go through all layers of hood, the rest only through the outer skin. Apply paint or sealant to holes to prevent rust.
9. Install hood bezel using supplied 1/8" black rivets. The long rivets go in the front and rear bottom holes through multiple layers of hood, the shorter are used on the rest of the locations (fig. 4). Extra of both rivets are provided in case of any issues. Suggest installing all rivets loosely before popping them.

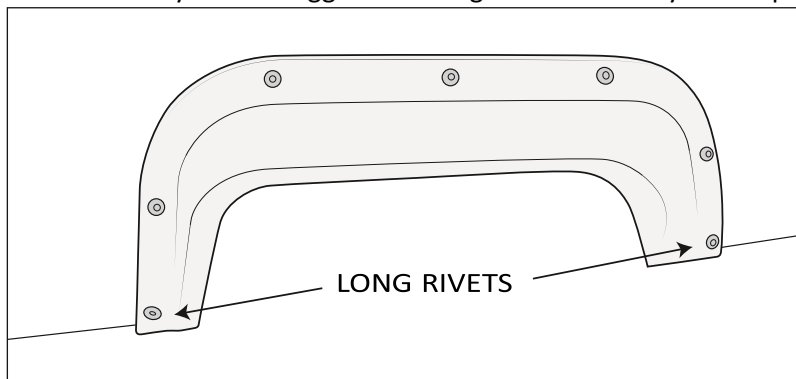

Figure 4



## II. REMOVE THE FACTORY AIRBOX

### 1. Remove airbox

- A. Loosen the clamp on the engine intake hose at throttle body and air box. Remove crankcase breather by squeezing grey fitting at air inlet and pulling rearward. Wiring connection does not need to be removed. Use a 10mm wrench or socket to remove two bolts holding intake hose to radiator support and SAVE. Pull intake hose off and set on radiator cover out of the way of the airbox (fig. 5).

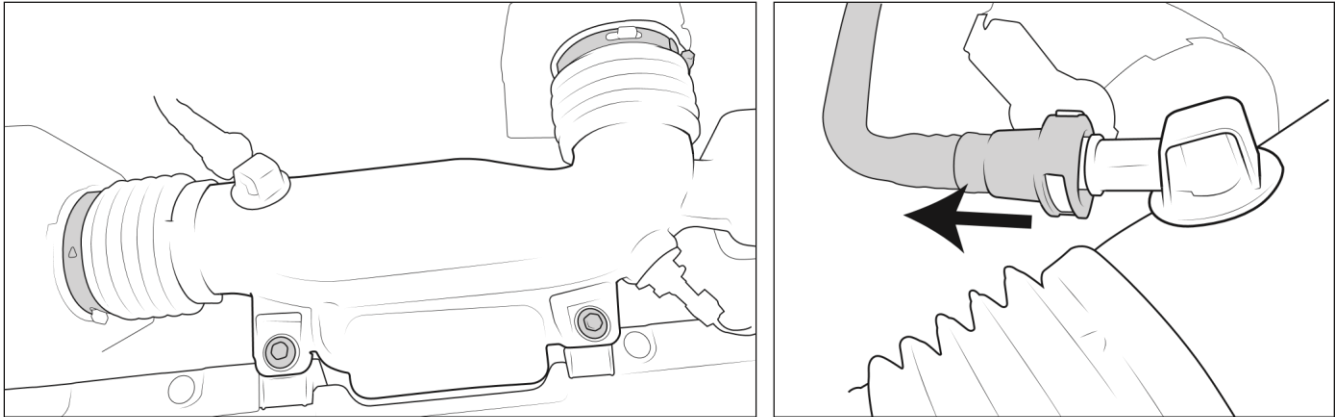

Figure 5

- B. Use M10 wrench or socket to remove the mounting bolt holding airbox inlet to fender and discard. This outboard bolt will not be reused, the two front intake hose bolts will be (fig. 6).

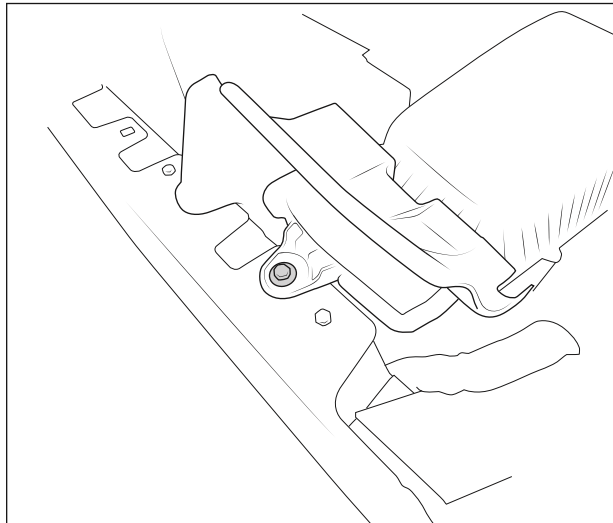

Figure 6

- C. Carefully lift airbox straight out of vehicle. There are press fit rubber bushings holding it in place, it will pop out with light force. If either of the rubber bushings comes out with the airbox, remove them from plastic studs and place back into the holes in the vehicle mount.
2. Remove the short factory inlet from the air box. You will need to pry it apart to unclip tabs from the airbox body.



### III. MOCK-UP THE SNORKEL ON VEHICLE

1. Install the large mounting bracket to the bottom of the snorkel using the provided M6 bolts and washers as shown (fig. 7). Make sure the bracket is straight and tighten bolts to 100 in-lb

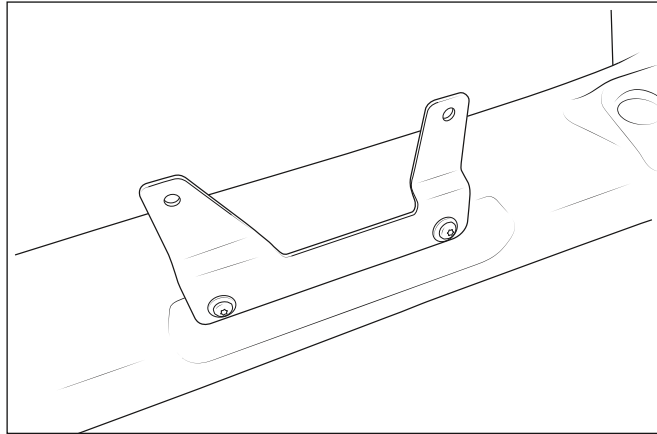

Figure 7

2. Remove the two rear and one front fender bolts (fig. 8) to prepare the vehicle for mounting the snorkel. These will all be reused.

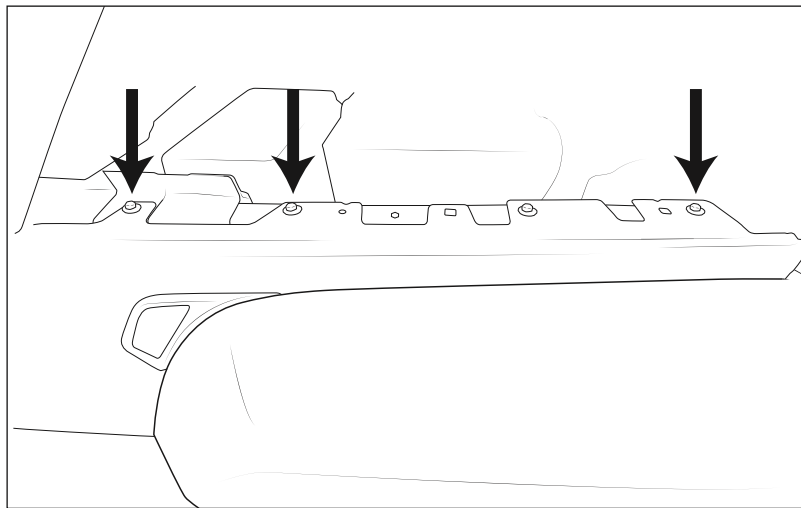

Figure 8



- Slide intake portion of AEV snorkel into airbox body until fully seated together (Note: MY24 3.6 L Airbox will need the ribs in the intake to be ground down until the AEV snorkel fully seats (Fig.9)). It will lock into the airbox the same way as the factory inlet. RTV or silicone is not required at this joint but can be added if desired for excessively dusty or wet conditions (fig. 10).

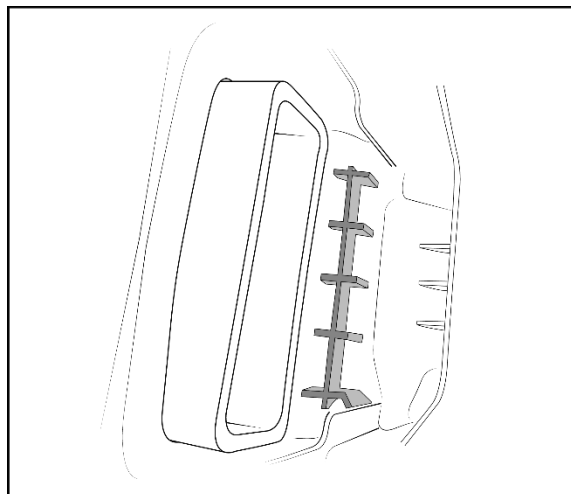

Figure 9

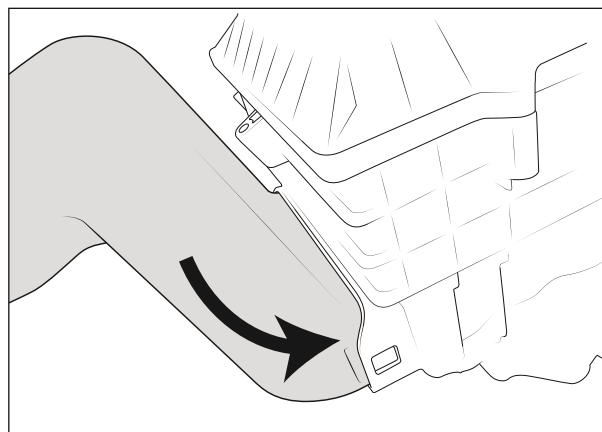

Figure 10

- Carefully lift snorkel and airbox assembly above fender and install into engine compartment. Be careful the mounting bracket does not damage the fender or paint.
- Loosely install two rear fender bolts into large snorkel bracket and tighten until just snug enough to hold snorkel body in place (fig. 11).

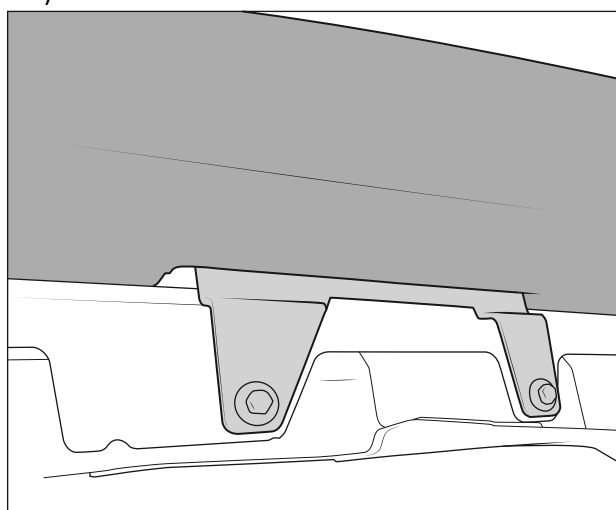

Figure 11

Figure 10

- Install the front mounting bracket using the front fender bolt. Place bracket over fender hole, loosely reinstall fender bolt, and bolt bracket into snorkel threaded insert with provided M6 bolt and washer (fig. 12). Tighten both until snug, but not fully torqued. Adjust lower snorkel body and brackets so that they sit



evenly with fender and cowl, without excessive gaps or any paint contact. Once snorkel is properly positioned, tighten front M6 bolt going into snorkel body to 100 in-lb.

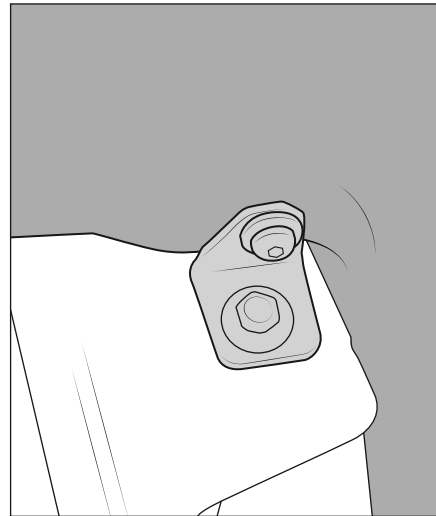

Figure 12

#### IV. INSTALL WINDSHIELD BRACKET

NOTE: If using the optional AEV A Pillar Mounting Kit Skip to section VI.

1. Place masking tape on the windshield frame in the area next to the indent on the upper portion of the snorkel. Install stamped mounting bracket to snorkel body as shown (fig. 13) and use provided M6 bolts and washers to loosely retain it. Adjust bracket so that it sits fully against windshield frame contour, hold it in place, mark the two accessible hole locations on the tape, then remove the bracket.

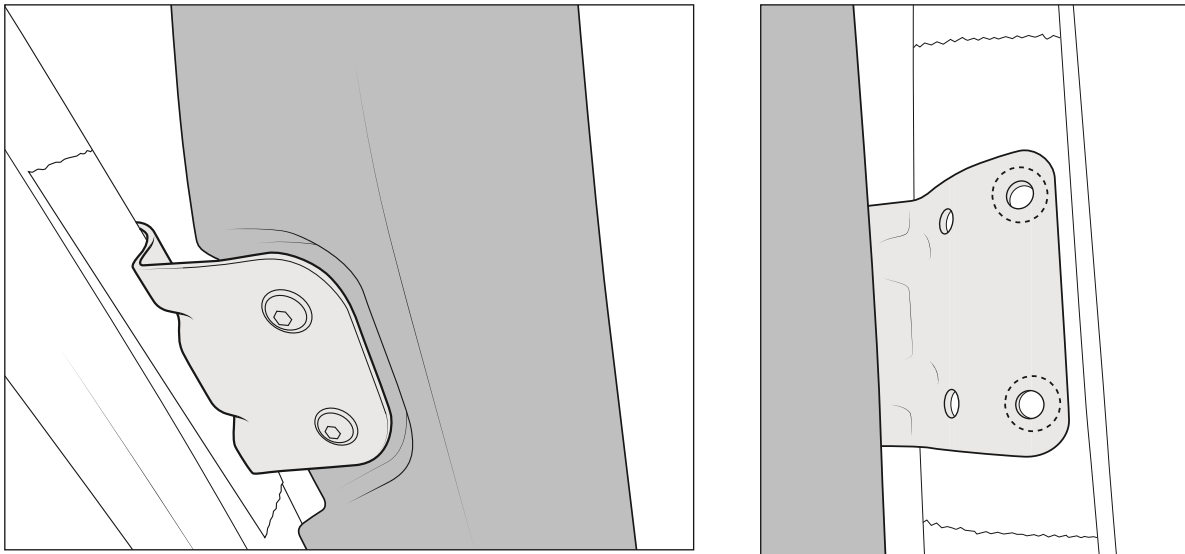

Figure 13

2. Remove snorkel/bracket/airbox assembly, being careful not to bump brackets out of position.
3. Hold windshield frame bracket in position on vehicle using two existing marks to position it and mark the remaining two holes. Remove bracket and drill all four windshield frame holes on center of marks to 3/16"





diameter, being careful to only pass through outer layer of material. Remove tape and apply rust prevention coating to holes. Install stamped bracket to windshield frame using 3/16" diameter black rivets. There's an extra rivet provided in case of any issues.

## V. PERMANENTLY INSTALL SNORKEL AND AIR RAM

NOTE: If installing optional A pillar mounting kit, we recommend performing section VI, step 1 now while snorkel is off of vehicle and mounting holes are easily accessible.

1. Reinstall snorkel and airbox assembly onto vehicle. Torque M6 bolts into snorkel body at windshield bracket (if applicable) to 100 in-lb. Reinstall fender bolts through snorkel brackets and torque to 20 ft-lb. Reassemble factory airbox and connections.
2. Install black isolator hose over antenna and slide all the way to antenna base.
3. Install air ram with provided clamp and tighten until snug enough to prevent lifting or twisting of the air ram (fig. 14). Channel locks or large pliers may be helpful to get clamp tight enough for good retention.

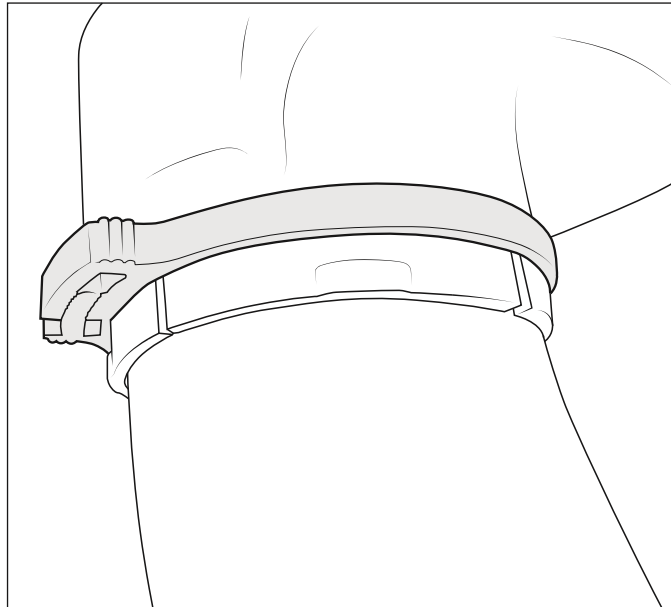

Figure 14

## VI. \*OPTIONAL\* A PILLAR BRACKET

NOTE: Due to vehicle-to-vehicle variation, make sure there's at least 3/16" gap between door frame and windshield frame in order to prevent paint damage. If less than 3/16", AEV recommends adding a washer between A pillar and windshield frame to space it forward slightly on vehicle and enlarge the gap.

1. Install provided studs into threaded inserts in side pocket of snorkel body (fig. 15). Due to coating on threads, it may be necessary to lock the 2 nuts together using 2 wrenches (fig. 16), then use a wrench on the outer nut in order to fully seat the studs. Once seated snugly into the snorkel insert, loosen the nuts from one another and remove them from the stud, then repeat procedure on the second stud, and set the nuts aside for use later.

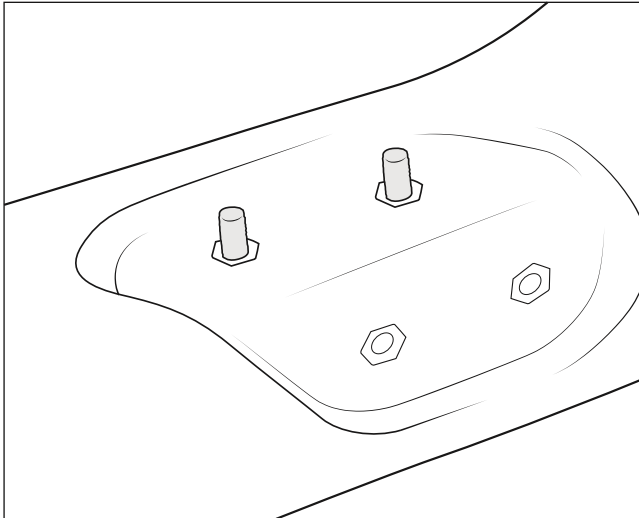

Figure 15

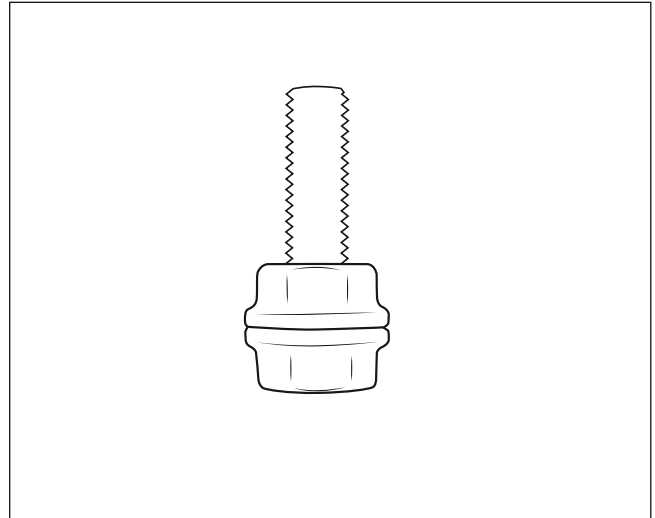

Figure 16

2. Clean surface of windshield frame, door, and A pillar inside of door opening. Measure 7.5" down from top edge of door frame and install one piece of paint protection film with large curved corners as shown (fig. 17). Align notches with door edge and stick down film with long side toward outside of vehicle. Slowly wipe down the sides from the door edge outward both directions to prevent bubbles.

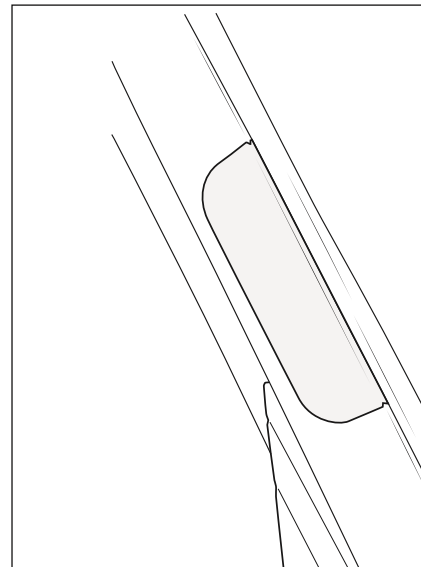
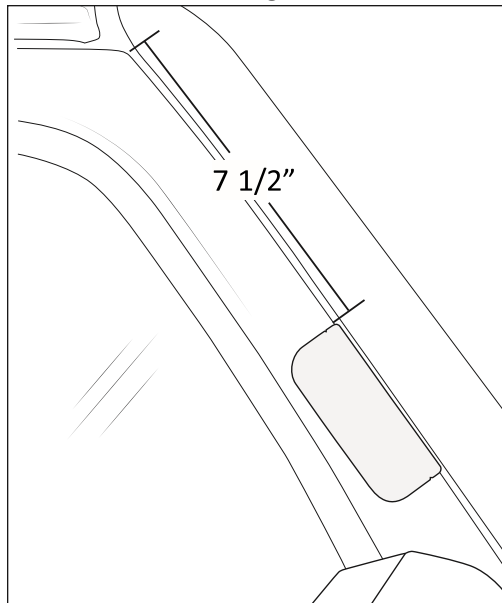
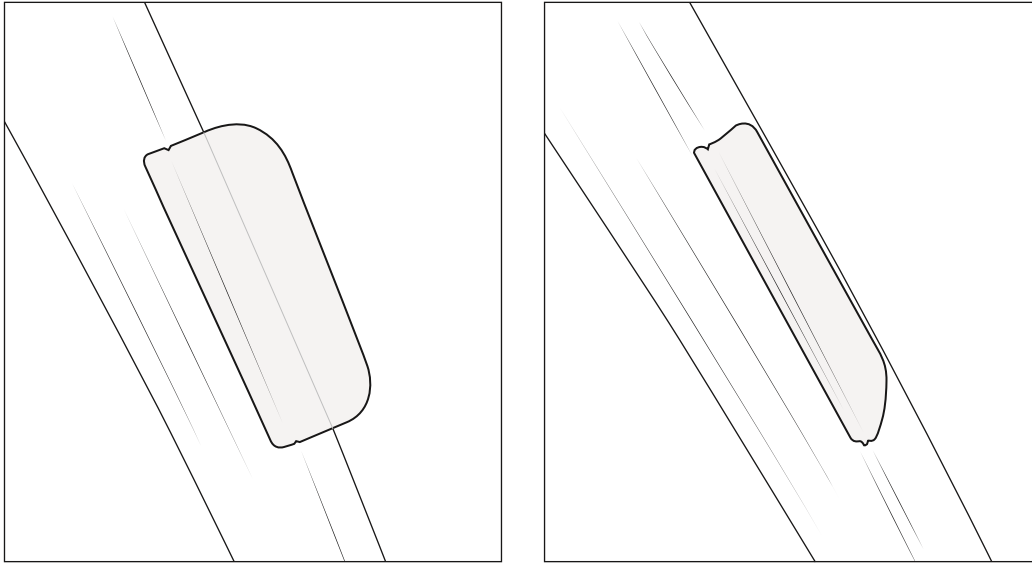

Figure 17

3. Close door and use tape or marker to mark windshield frame at bottom edge of door paint protection film. Open door and install matching piece of film to windshield frame using same procedure as door. (fig. 18).



*Figure 18*

4. Install remaining piece of paint protection frame to door seal section of windshield frame. Align bottom edge with film on windshield frame as shown, again being careful to stick down gradually and prevent bubbles (fig. 19).

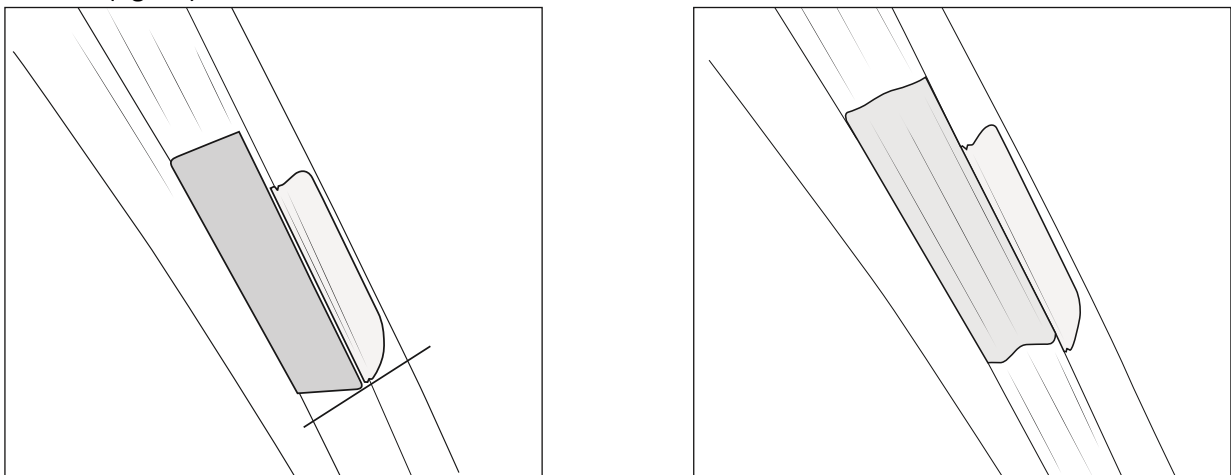

*Figure 19*

5. Unclip endcaps around A pillar grab handle (fig. 20).

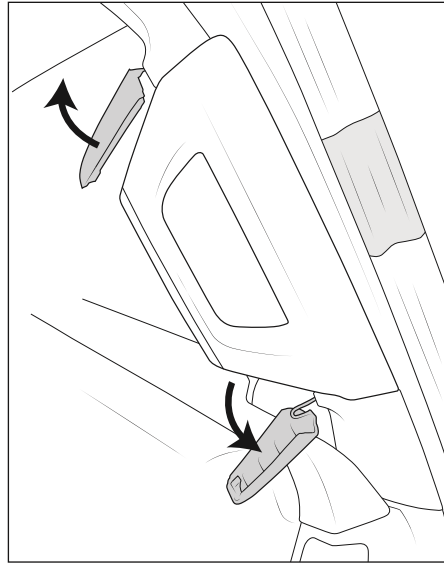

*Figure 20*

6. Use M10 socket and extension to remove mounting bolts retaining grab handle and trim panel to A pillar (fig. 21). Pull handle straight out from A pillar to unclip it.

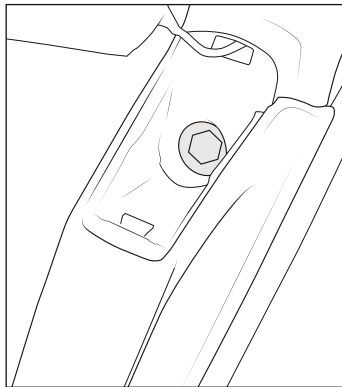

*Figure 21*

7. Install AEV mounting bracket to snorkel body using provided M6 studs and nuts. Keep loose at this time. Make sure bracket sits underneath wiring on A pillar.
8. Hold bracket in position so square cutout and mounting holes line up with matching holes in A pillar (fig. 22). Reinstall trim panel/grab handle and hold in position while reinstalling bolts. Tighten bolts to 100 in-lb.

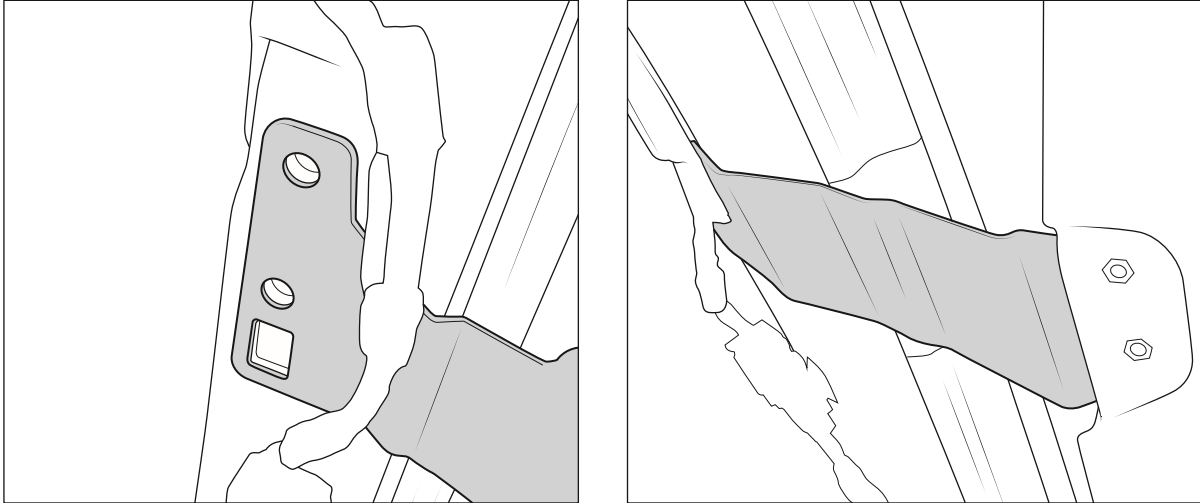

Figure 22

9. Tighten M6 nuts on snorkel body studs to 100 in-lb. (fig. 23).

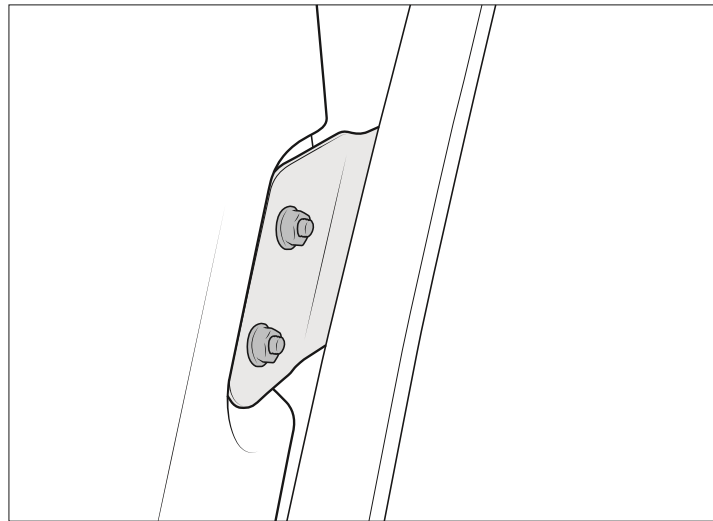
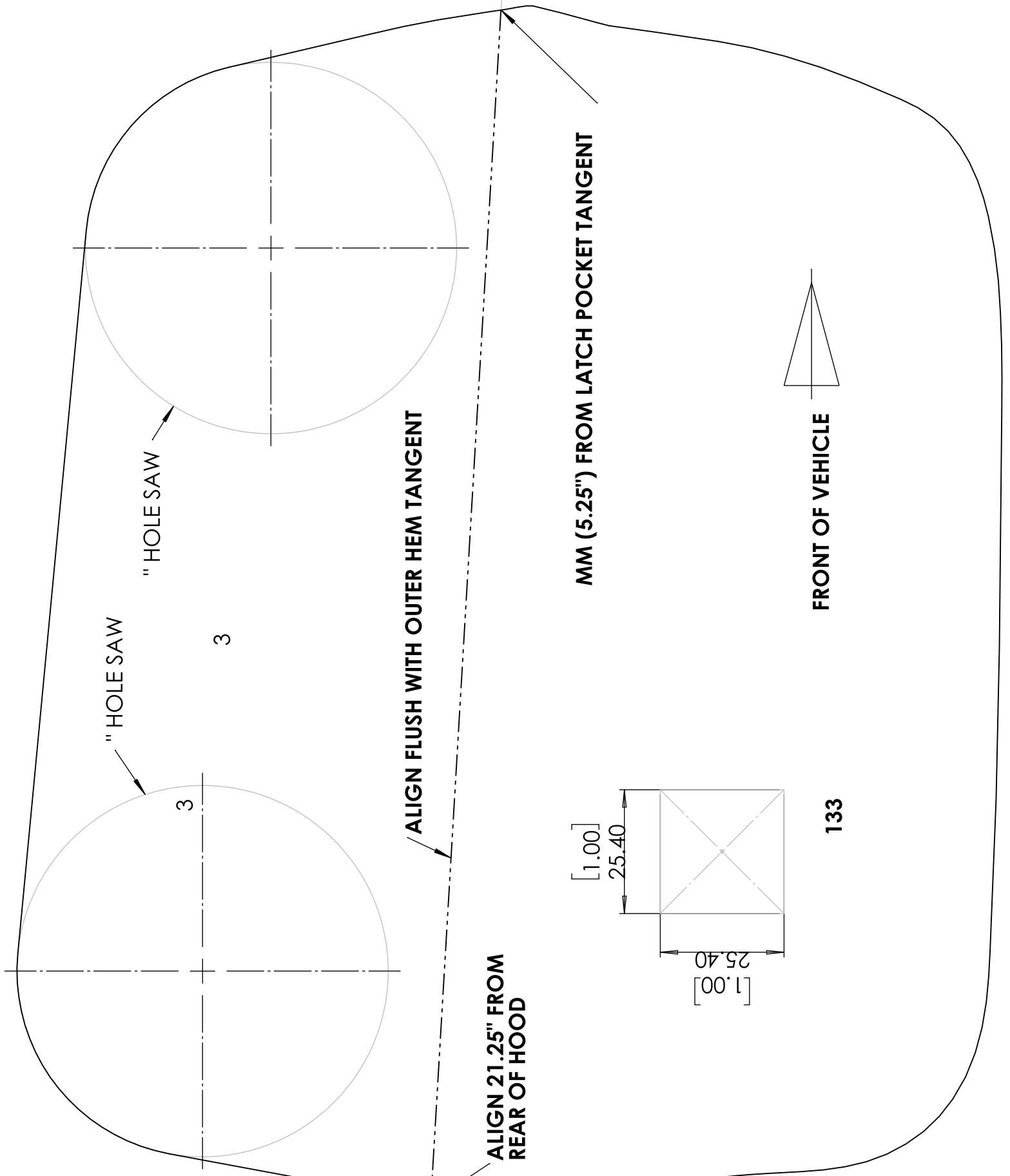

Figure 23

## VII. SNORKEL USAGE AND CARE

This product is intended to provide clean, dry air to the engine but does not necessarily mean the vehicle can exceed the manufacturer's recommended fording depth. There are many considerations to make when increasing fording depth and a snorkel is just one small part. While a snorkel can be a real lifesaver in an occasional accidental deep water crossing, the benefits can most easily be seen in every day dust prevention — especially when equipped with the optional pre-filter.



" HOLE SAW

" HOLE SAW

3

3

ALIGN FLUSH WITH OUTER HEM TANGENT

ALIGN 21.25" FROM REAR OF HOOD

MM (5.25") FROM LATCH POCKET TANGENT

FRONT OF VEHICLE

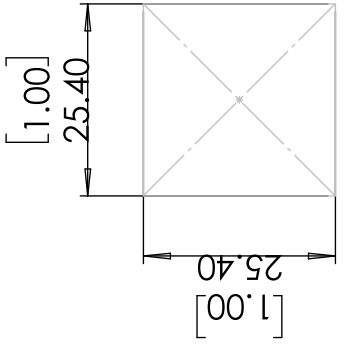

133