



3" DUALSPORT FRONT SUSPENSION

2019+ RAM 2500/3500

INCLUDED PARTS	QTY	REQUIRED TOOLS
Coil Spring Mount & Bumpstop Kit – Front	1	Common hand tools
Radius Arm & Track Bar Bracket Kit – Front	1	Quality torque wrench capable of 324 ft-lb
Draglink & Track Bar Kit – Front	1	Bright colored paint marker
Shocks – Front PN: F4-241557 (Diesel) F4-24246002-MO (Gas)	2	Abrasive cutoff wheel or metal saw (trimming may be required in step 19-B)
Driveshaft Spacer Kit	1	
AEV RH Steering Knuckle	1	

AEV30407AE

Last Updated: 06/19/26

PLEASE READ BEFORE YOU START

TO GUARANTEE A QUALITY INSTALLATION, WE RECOMMEND READING THESE INSTRUCTIONS THOROUGHLY BEFORE BEGINNING ANY WORK. THESE INSTRUCTIONS ASSUME A CERTAIN AMOUNT OF MECHANICAL ABILITY AND ARE NOT WRITTEN NOR INTENDED FOR SOMEONE NOT FAMILIAR WITH AUTO REPAIR.



IMPORTANT: IMPROPER NUT TORQUE COULD CAUSE STEERING FAILURE. Proper clamp load is critical on the draglink to knuckle interface. The nut **MUST** be torqued to 100–110 ft-lb using a torque wrench. Drag link should also be inspected and the nut torque checked after 500 miles and at each oil change. Do not install using an impact gun or a “tight enough” mentality. They must be properly torqued to the specified range using a torque wrench.

NOTE: Installation on a Powerwagon requires the purchase of new Coil Springs, Mopar PN: 68505958AB (front) and 68349171AB (rear).

NOTE: If installing with the factory front bumper, some trimming of the bumper will be necessary.

NOTE: If running smaller than 20” wheels, 6” or less of backspacing is required. Factory 18” wheels will not clear top-mount draglink.



FRONT SUSPENSION 2500/3500

A. FRONT SUSPENSION PREPARATION

NOTE: SAVE ALL HARDWARE UNTIL INSTALLATION IS COMPLETE.

1. Support the vehicle by the frame until the front wheels are off the ground.
2. Remove the front wheels and tires.
3. Remove the drag link.
 - A. Measure from center of pitman arm tie rod stud to center of passenger side knuckle stud. Record the length for reference when setting new draglink length.

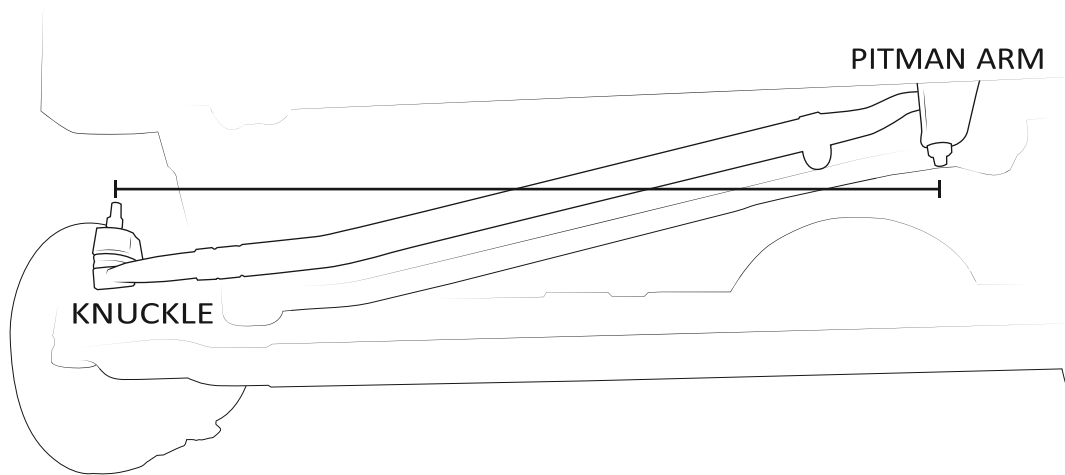

- B. Loosen clamp at threaded adjuster.
- C. Remove the drag link at the axle end.
- D. Thread adjuster sleeve and draglink out until separated from pitman arm tie rod (fig. 1).

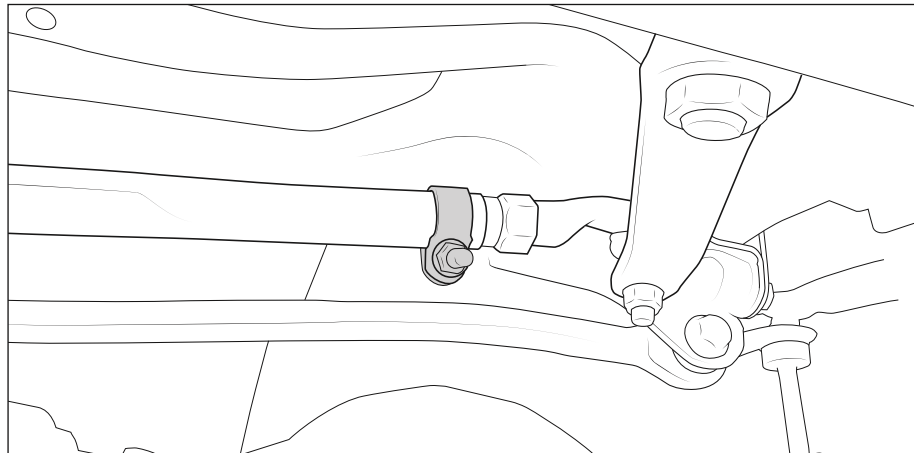

Figure 1

- E. Adjuster can be discarded along with original draglink.



4. Remove the track bar and save the axle end hardware.
5. Remove the sway bar links at the axle end only.
6. Remove the steering damper bolt at the axle. Leave attached at the tie rod.
7. Remove the front brake lines.
 - A. Clamp off the flexible brake lines (fig. 2).
 - B. Remove the steel brake lines between the two flexible lines (fig. 3).
 - C. Remove the flexible line brackets at the top of the radius arms and let hang (fig. 4).

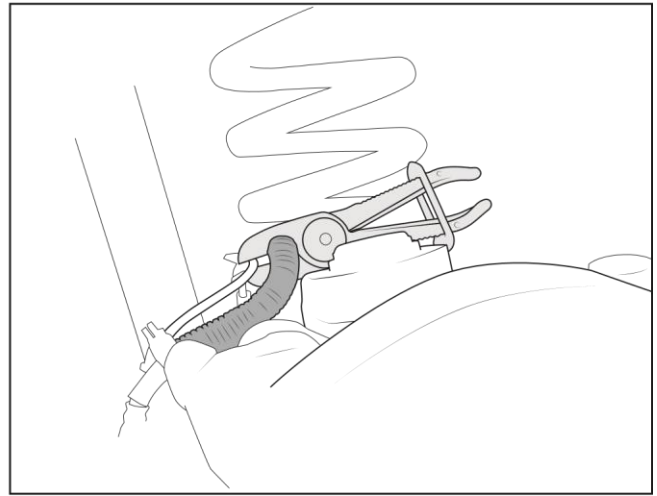
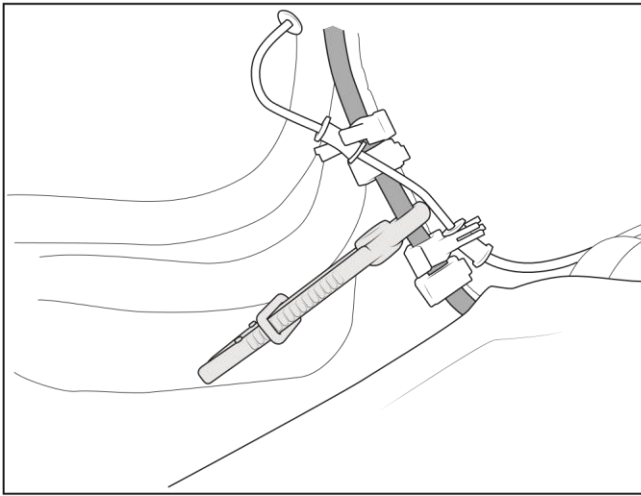

Figure 2

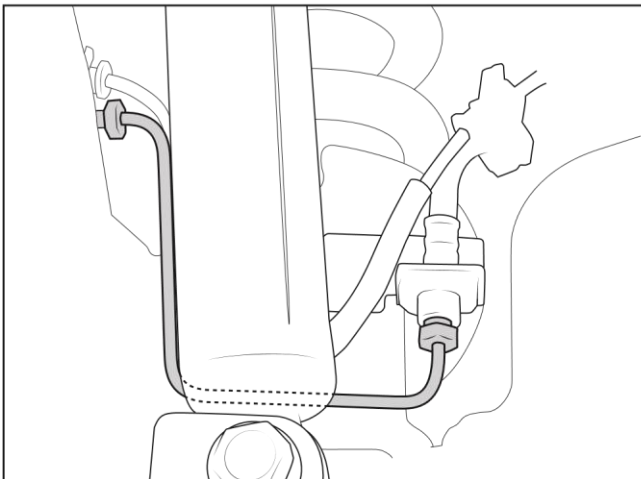

Figure 3

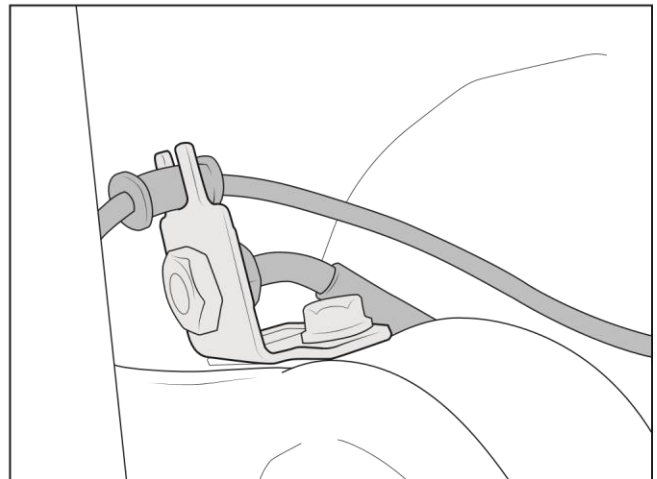

Figure 4

8. Unplug the central axle disconnect and remove the zip tie (fig. 5).
9. POWER WAGON ONLY – Disconnect the front locker plug and remove the zip tie from the axle (fig. 6).

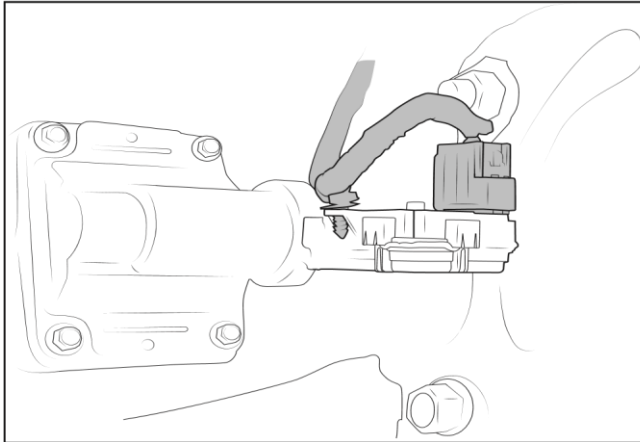

Figure 5

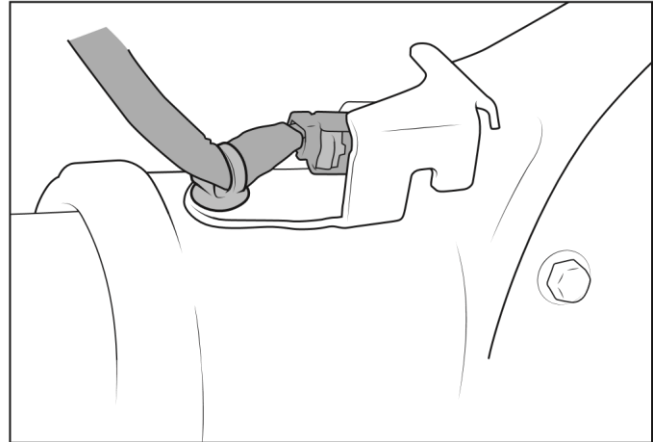

Figure 6

10. Remove the axle vent from the brake line bracket and shock tower (fig. 7).

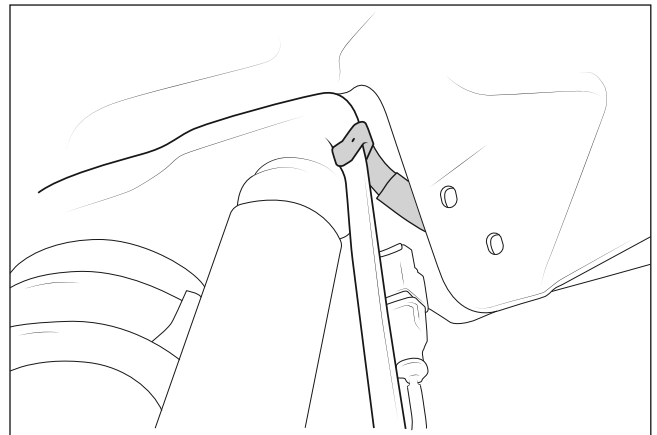
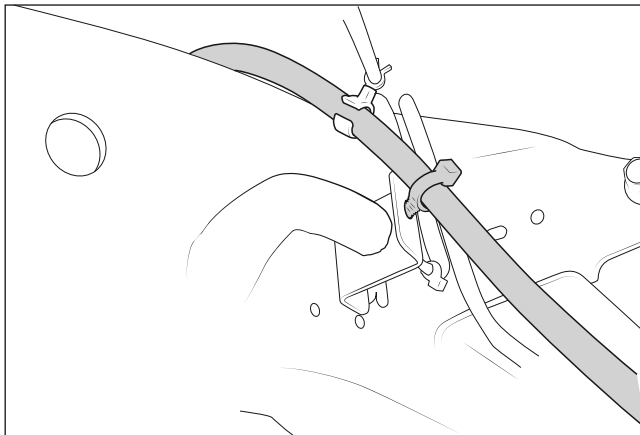

Figure 7

11. Disconnect the front drive shaft at the axle end. Make sure to mark both sides of the connection so you can properly align it when you reconnect it. Tie loose end of the drive shaft up so it will not hang down. Failure to follow this step may result in damage to your drive shaft.
12. Support the front axle and remove the shocks.
13. Lower the front axle enough to remove the front coil springs. Check to make sure the brake lines are not catching on anything.
14. Remove the lower coil spring isolators from the axle.
15. Using the AEV right side coil spring mount (NRMS1000) as a template, mark and trim the factory coil bucket as shown (fig. 8). Paint bare metal for corrosion protection.

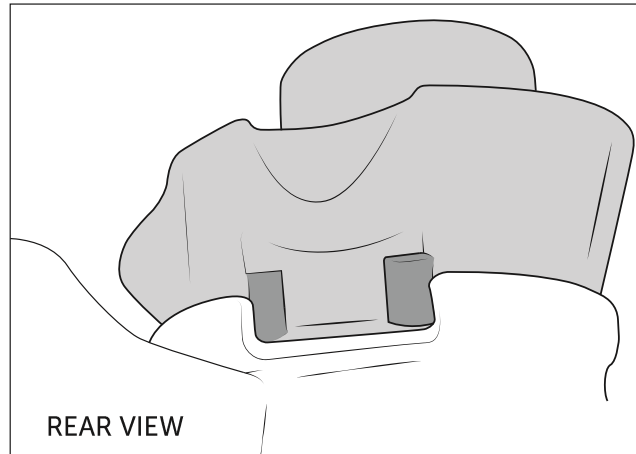

Figure 8-A: Center Coil Spring mount in Bucket Using Rear Tab

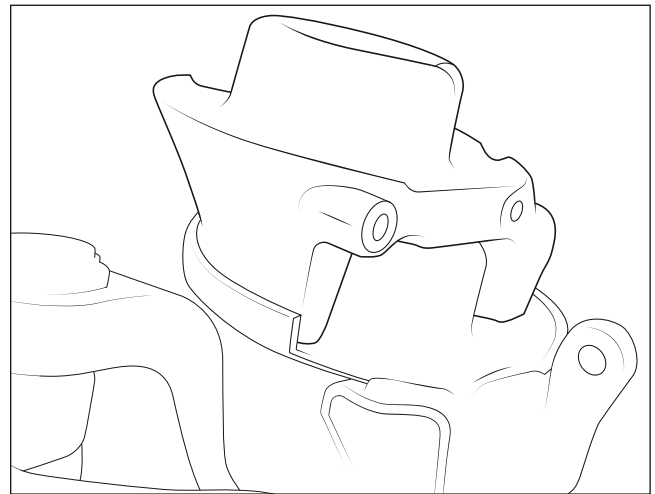
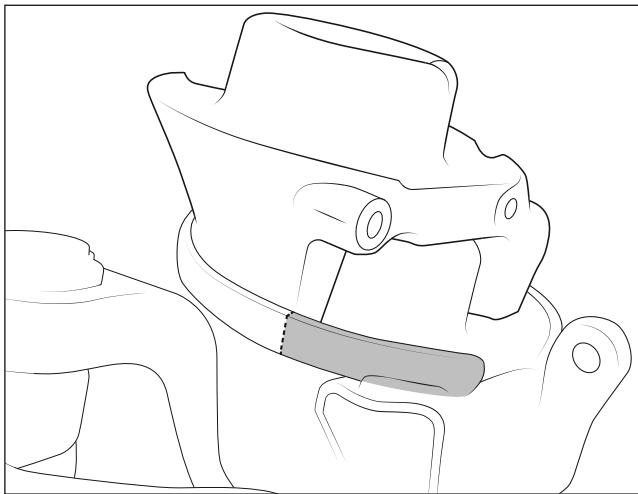

Figure 8-B: Remove Shaded Portion

B. FRONT SUSPENSION INSTALLATION

1. Install the radius arm relocation brackets using hardware bag #1.

A. Preassemble the AEV radius arm brackets using M10 x 45 Carriage Bolts, M10 Flat Washers and Nuts (Fig. 9). Note the additional spacer for 40" tire applications.

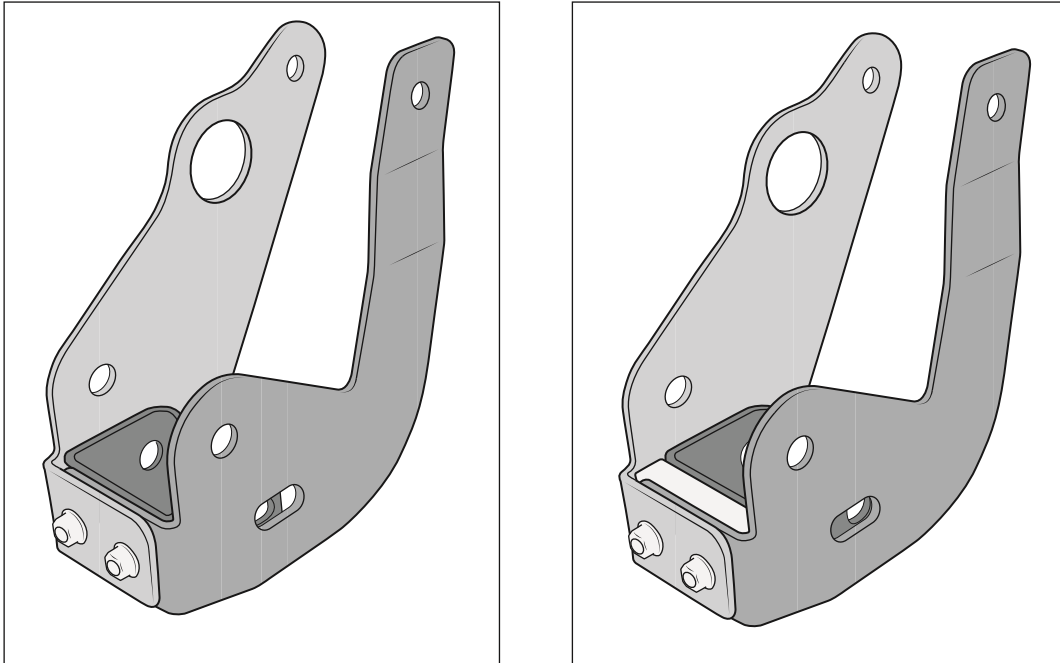

Figure 9 Left: 37" Tires Right: 40" tires

- B. GASOLINE TRUCKS ONLY: Remove active vibration dampers from framerail and wiring harness (fig 10).

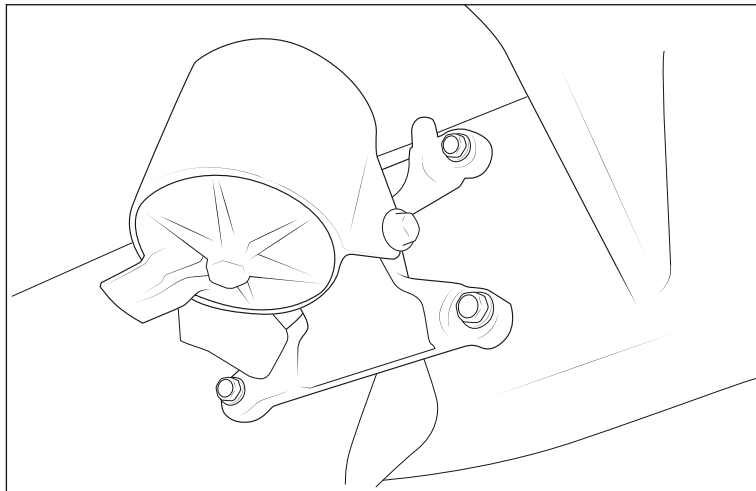

Figure 10

- C. With the front axle still supported, remove one radius arm bolt at the frame.
- D. Lower the radius arm enough to put the radius arm brackets and spacer in place.
- E. Install the supplied spacer from outer side of the frame rail as shown (fig. 11). Make sure inner portion of the spacer passes through hole on the inside of framerail as well.

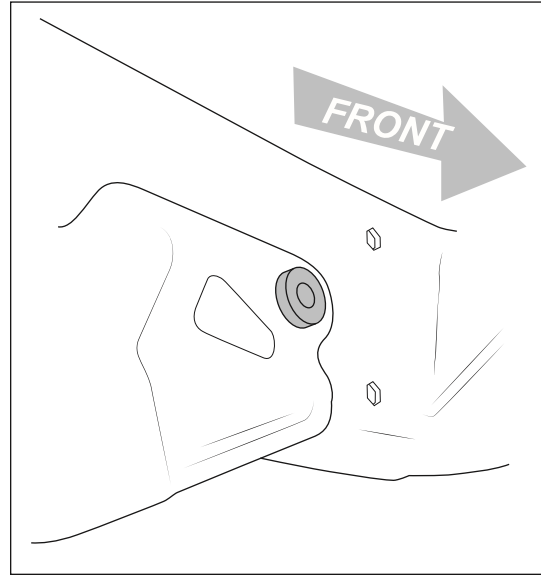

Figure 11

- F. Install the brackets to the frame with the supplied hardware (leave loose at this time) (fig. 12). NOTE: The M18 X 130 bolts MUST go in the original radius arm hole. The M18 X 140 will interfere with the cross member.

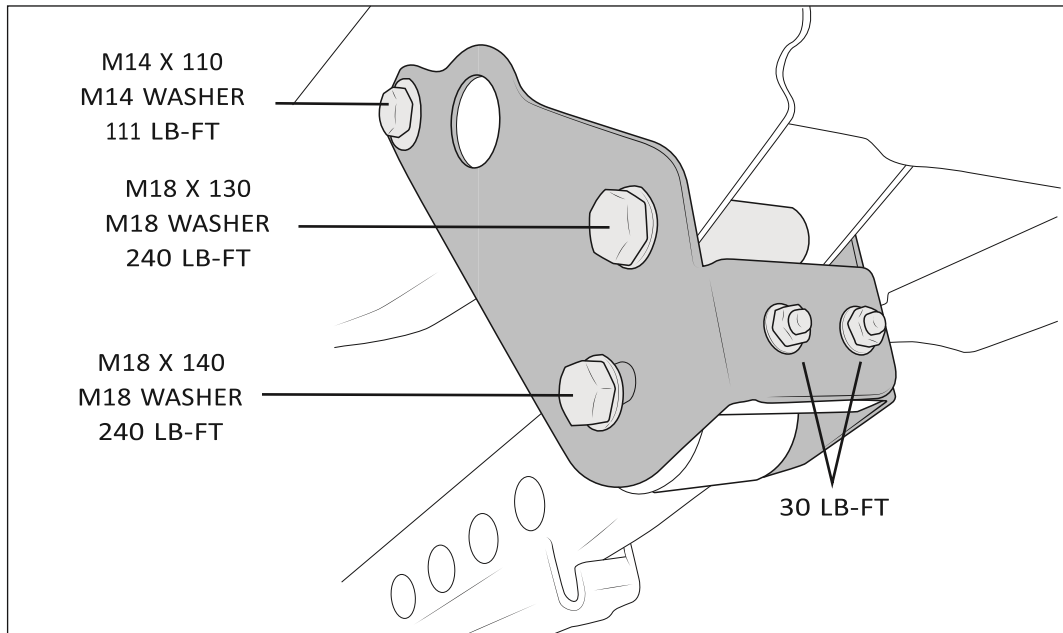



Figure 12-A

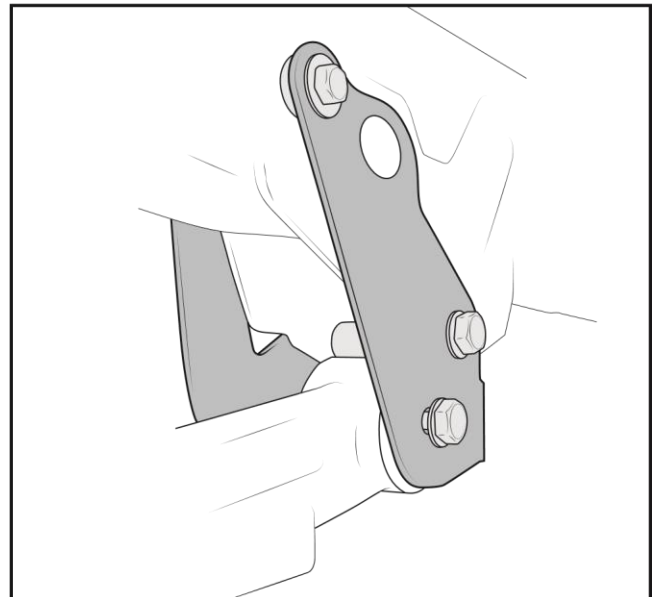
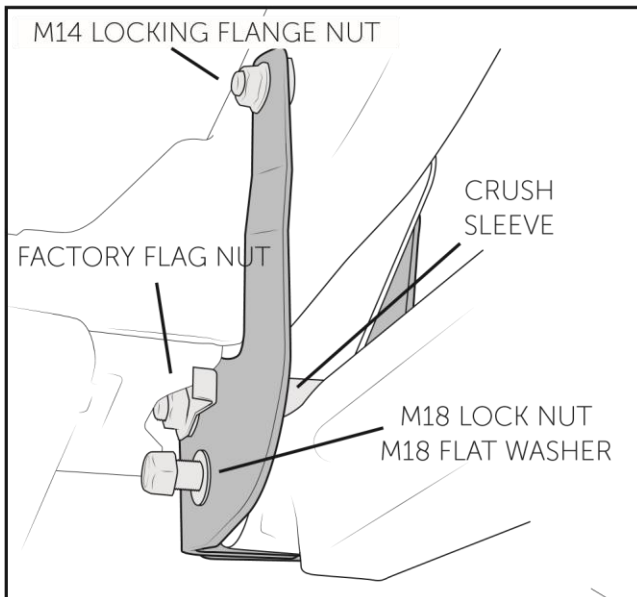

Figure 12-B

- G. Insert the M18 X 140 bolt through the radius arm.
- H. Repeat the process on the other side.
- I. Tighten and torque all hardware except the radius arm bushing through bolts (These will be tightened later at ride height). Refer to figures 11-A and 11-B for torque specifications.
- J. GASOLINE TRUCKS ONLY: Reinstall active vibration dampers over AEV radius arm brackets using supplied spacers and hardware (fig. 13). Torque to 25 ft-lbs.

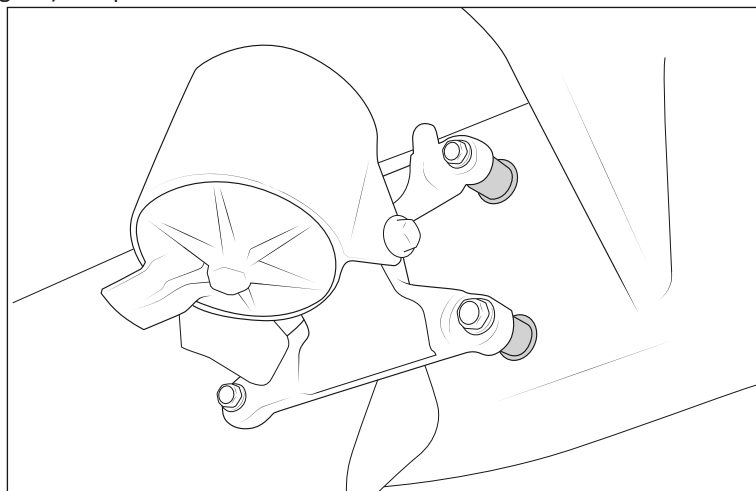

Figure 13



NOTE for 3500 Trucks with the AISIN AS66RC Transmission upgrade: The chassis wiring harness will contact the front drive shaft at full extension (fig. 14) and must be relocated. Disconnect the wiring harness from the frame so it can be moved further to the rear of the vehicle. Zip-tie in place using existing holes in the frame.

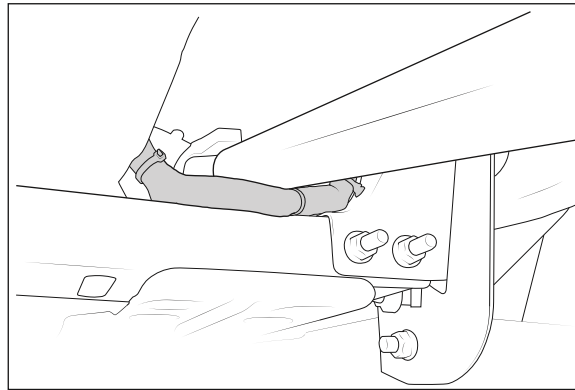

Figure 14

2. Install the sway bar relocation brackets using hardware bag #3 (fig. 15).
 - A. Remove one side of the sway bar at the frame and loosen the other side.
 - B. Install one side at a time and torque all fasteners (fig. 14).

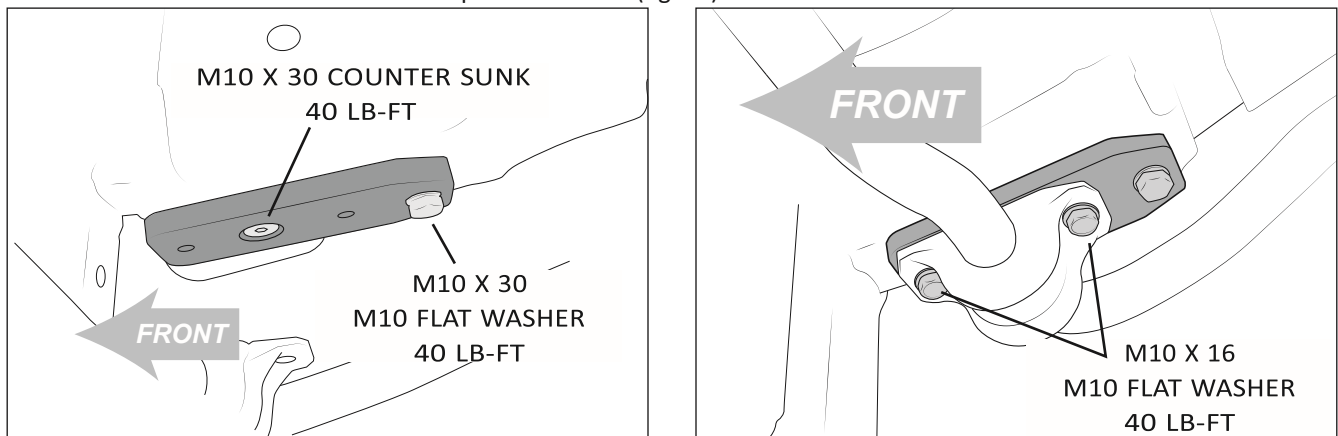

Figure 15

3. Remove any debris in the factory coil bucket.
4. Install AEV coil spring mounts to the axle using hardware bag #2. Leave loose at this time (fig. 16).

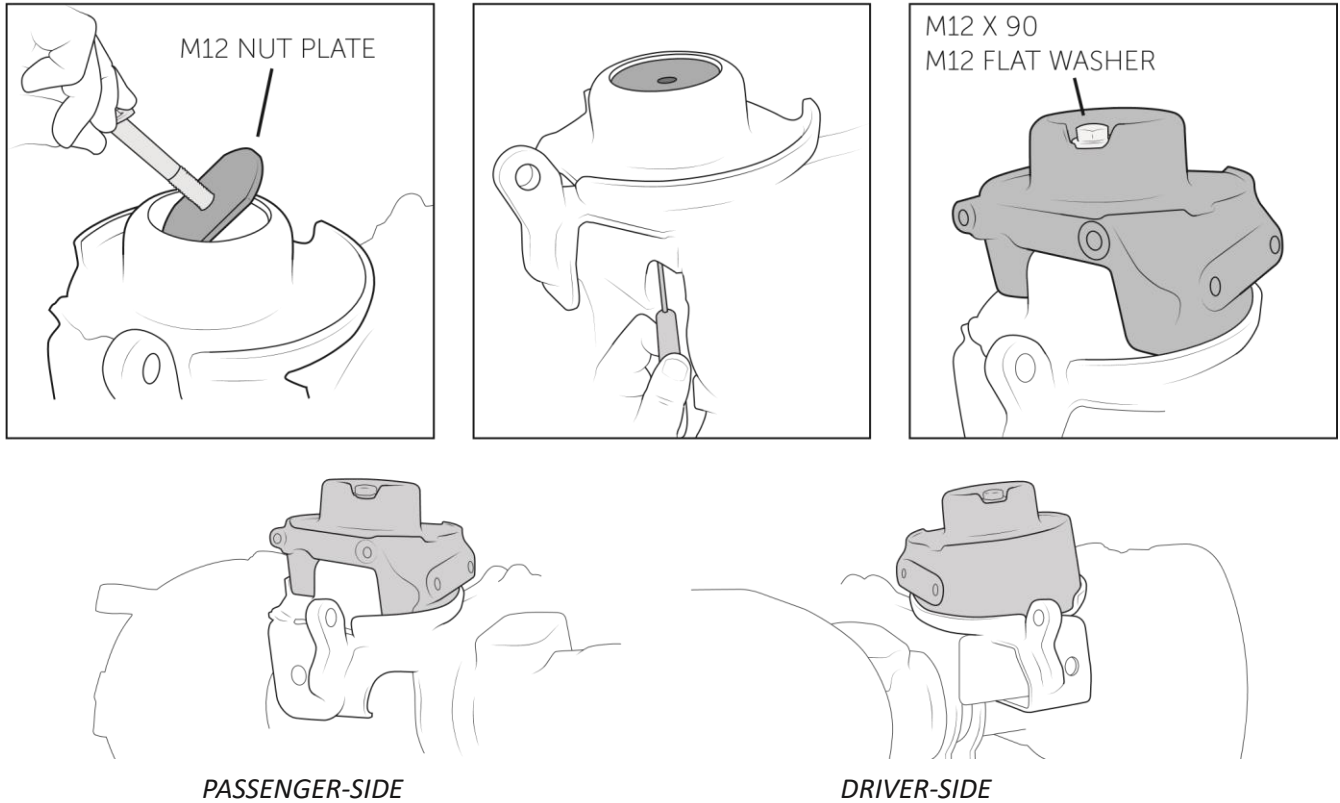

Figure 16

5. Install the track bar relocation brackets using hardware bag #4.

A. Remove the two upper bolts from the steering dampener bracket at the axle (fig. 17).

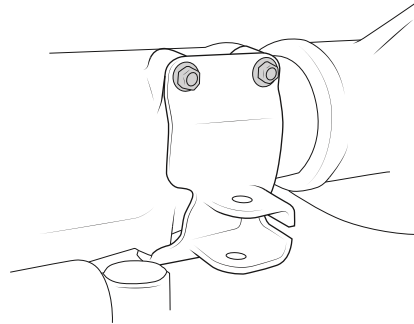

Figure 17

B. Install the rearward track bar bracket to the new coil spring mount and axle using the supplied hardware. Leave loose at this time (fig. 18). NOTE: snug the M10 x 25 button head bolts as far as possible while still allowing for movement.

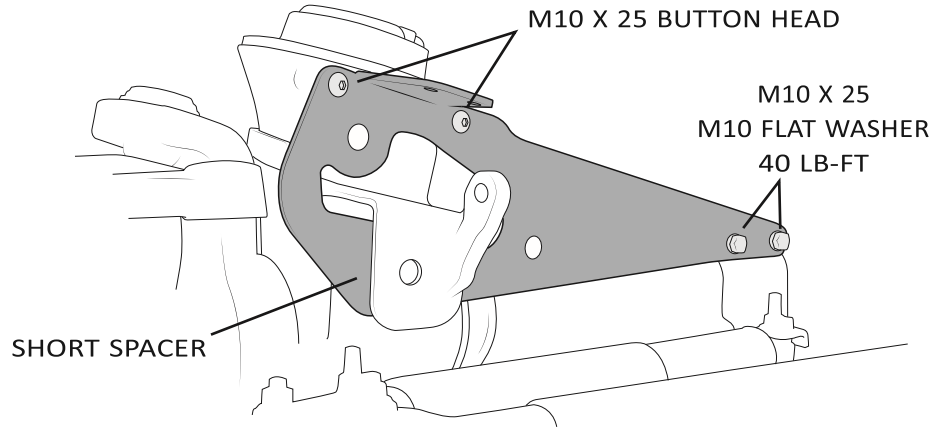
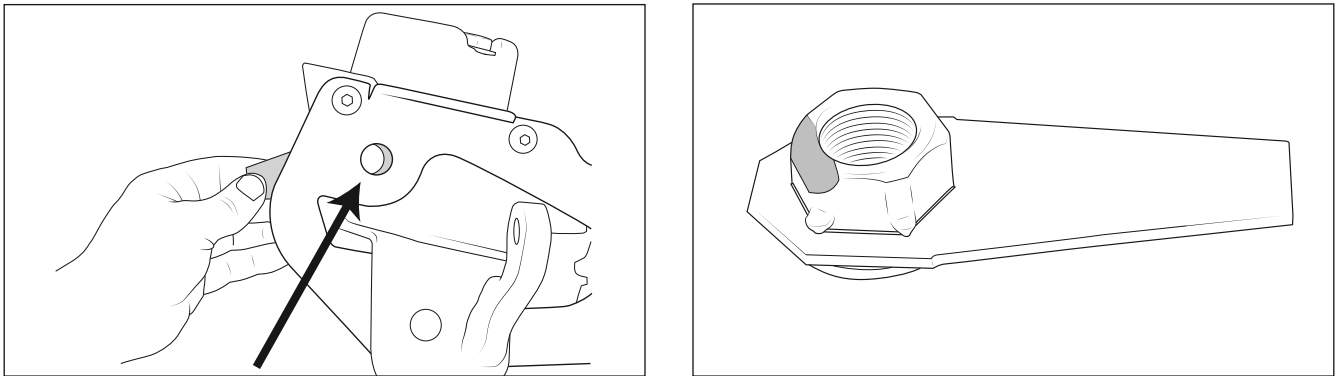

Figure 18

- C. The tab nut off of the frame side track bar bolt will be used for the axle side track bar bolt. The edge will need beveled to fit. Hold it up to the hole and check for clearance and bevel as needed (fig. 19).



- D. Position the forward track bar bracket and insert the sway bar links back in the factory location and torque to 110 lb-ft before installing any hardware (fig. 20).

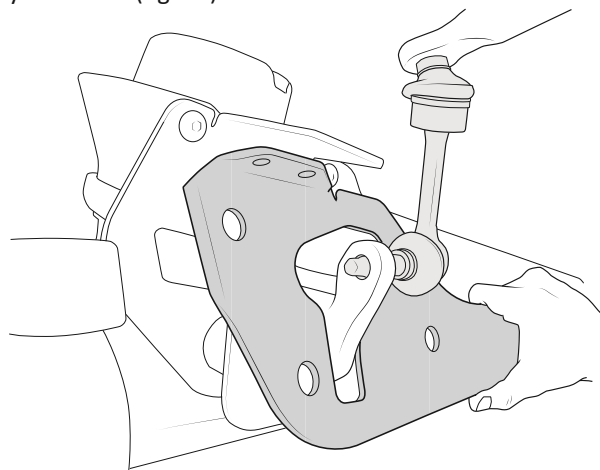

Figure 20

- E. Install the supplied hardware, factory hardware, and spacers into forward track bar bracket. Leave loose at this time (fig. 21).

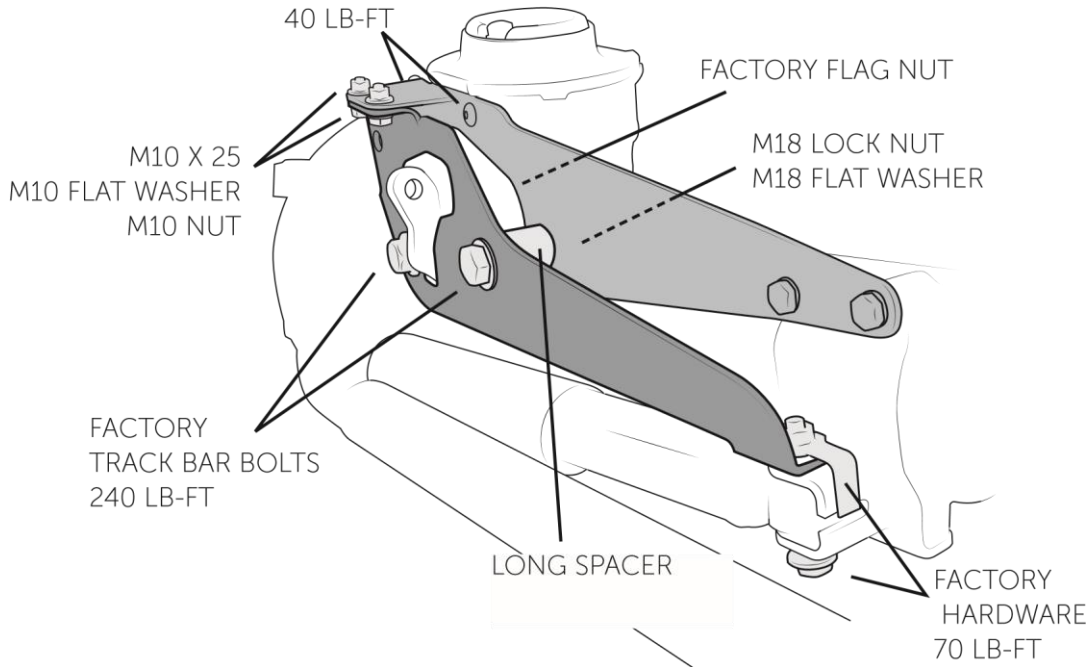

Figure 21 (sway bar link removed for clarity)

6. Installing the AEV track bar.

A. Remove factory frame-side track bar bracket from frame. **SAVE** hardware and discard bracket (fig. 22).

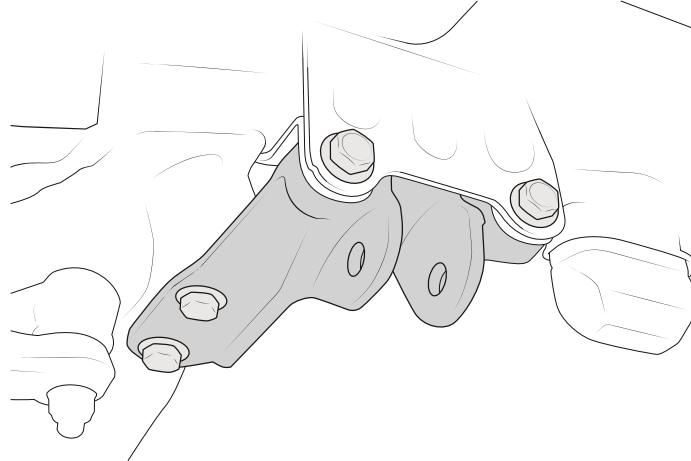

Figure 22

B. Install AEV supplied frame bracket (fig. 23). Reuse factory hardware into the frame weld nuts. In vertical frame flange, reuse factory bolt with AEV supplied nut **ONLY** at front location. At rear bolt hole, use AEV supplied M16 button head bolt and nut. Install bolt from outside of bracket. Starting with vertical bolts, torque M14 to 118 ft-lbs. Torque M16 button head to 140 ft-lbs.

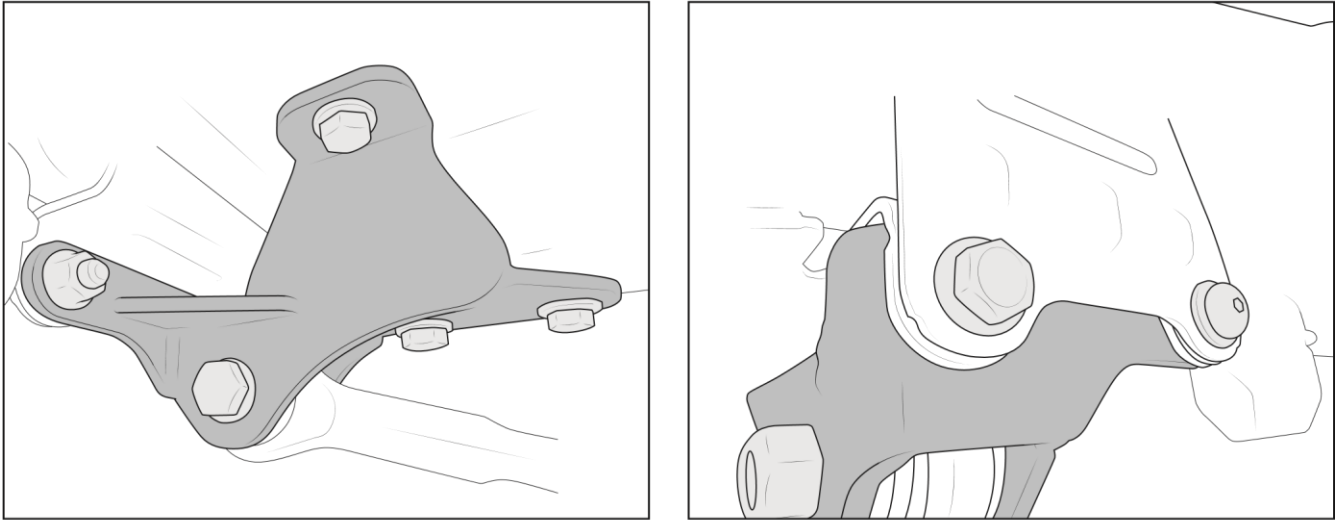

Figure 23

- C. Install track bar to axle end first using the supplied m18x70 bolt and washer with the factory frame-side tab nut (leave loose at this time).
- D. Install supplied M18x90 bolt, washer, thick spacer, and locking flange nut on the AEV frame bracket. Pass the bolt through from the rear of the vehicle to the front. NOTE: If installed backward the bolt can interfere with the axle during suspension movement. The track bar should be installed toward the rear of the bracket with AEV supplied thick spacer between track bar and front tab of bracket (fig.24).

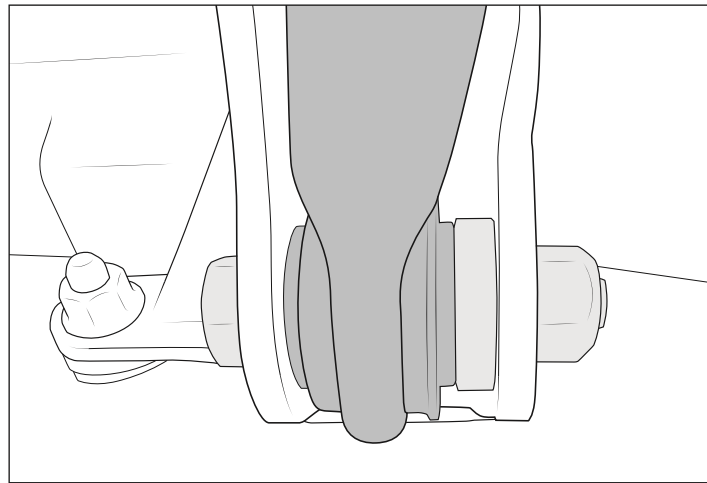

Figure 24

7. Install the brake line/bump stop brackets and the bump stops.

- A. Pre-assemble the brake line/bump stop brackets to the bump stops as shown (fig. 25). Only snug bolts at this time, you will need movement to adjust position on vehicle.

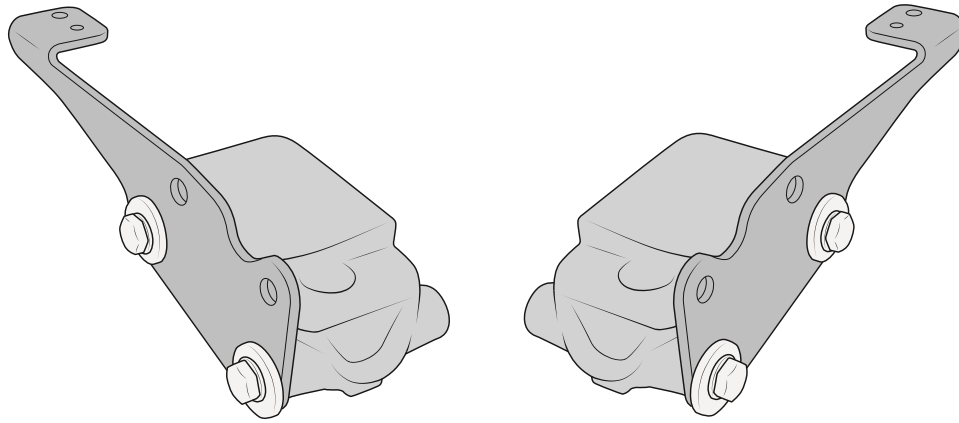

Figure 25

- B. Place the bump stop/bracket assemblies on the axle and start the bolts into the coil spring mounts. Secure with M10 X 25 countersink bolts and lightly snug to align (fig. 26).

NOTE: Due to some variations in axles modification of the driver-side coil bucket **MAY** be required. If the coil bucket is making contact with the brake line bracket and not allowing for proper seating, then it is necessary to remove that portion of the coil bucket (fig. 27).

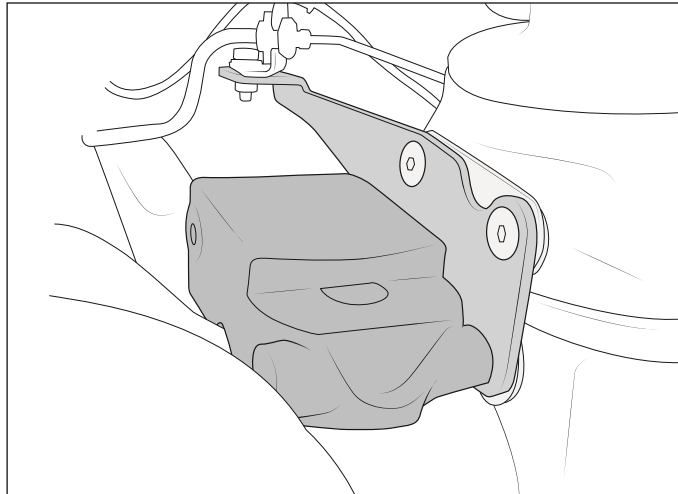

Figure 26

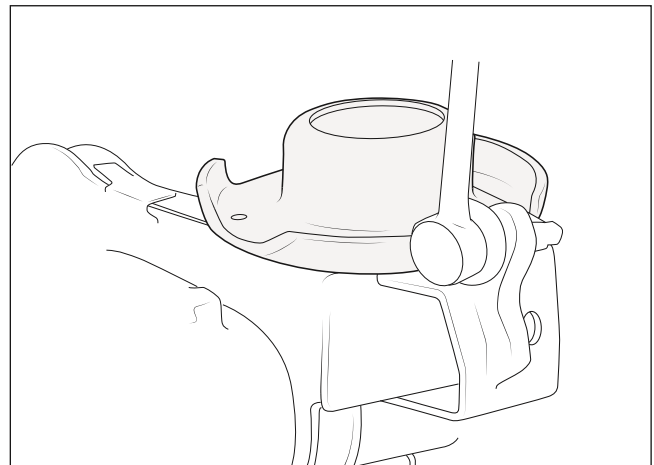
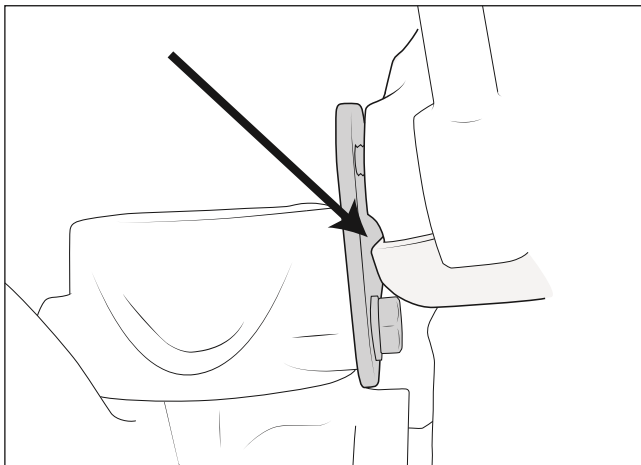

Figure 27: Trim driver-side coil bucket **IF NECESSARY**



- C. Rotate the coil spring mount to make the mating surface of the bracket parallel to the coil spring mount.
- D. Snug one bracket to bump stop bolt one each side making sure bump stops are seated properly.
- E. Remove the bump stop/bracket assemblies and torque BOTH bolts to 40 lb-ft Return assemblies to the axle once tight.
- F. Start the rearward bolt into the coil spring mount.
- G. There may be a gap between the bumps top and coil spring mount. Use the supplied shims to shim as shown (fig. 28).
- H. Start the other bolt through the shim.
- I. Tighten both coil spring mount to the axle. NOTE: Only snug these by hand, overtightening will deform the nut plate.
- J. Torque the bump stop/bracket assemblies to the coil spring mounts to 40 lb-ft
- K. Repeat shimming process on other side.

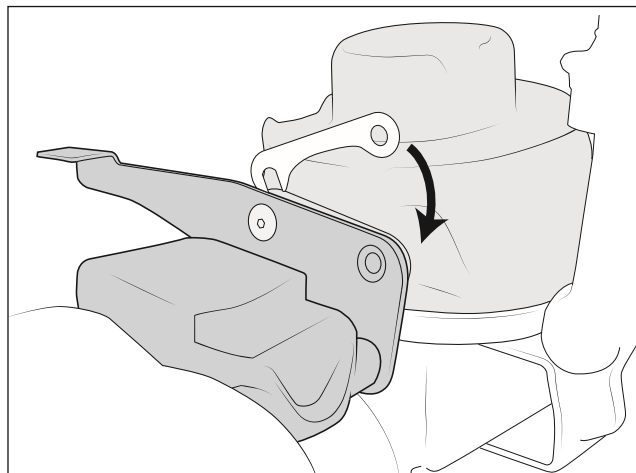

Figure 28



8. Install the factory coil spring isolators to the AEV coil spring mounts (fig. 29).
9. Install the factory coil springs. Due to frame bracket variation, some trucks may require trimming of this factory bracket on either or both sides of the vehicle to clear the relocated coil springs (Fig. 30)

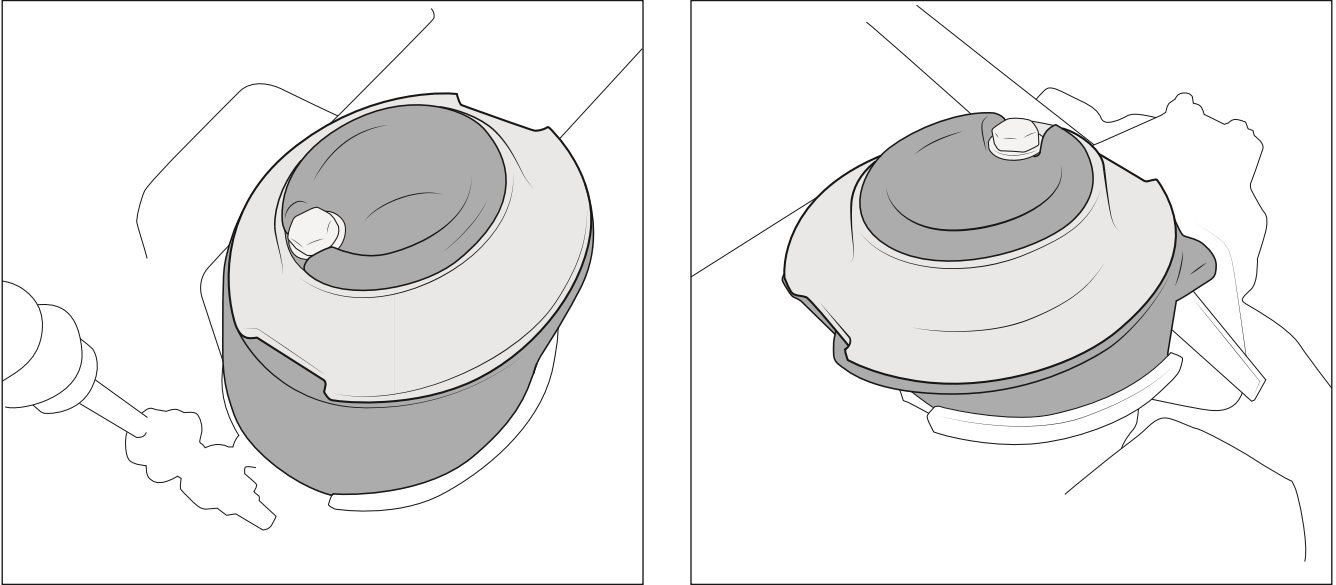

Figure 29

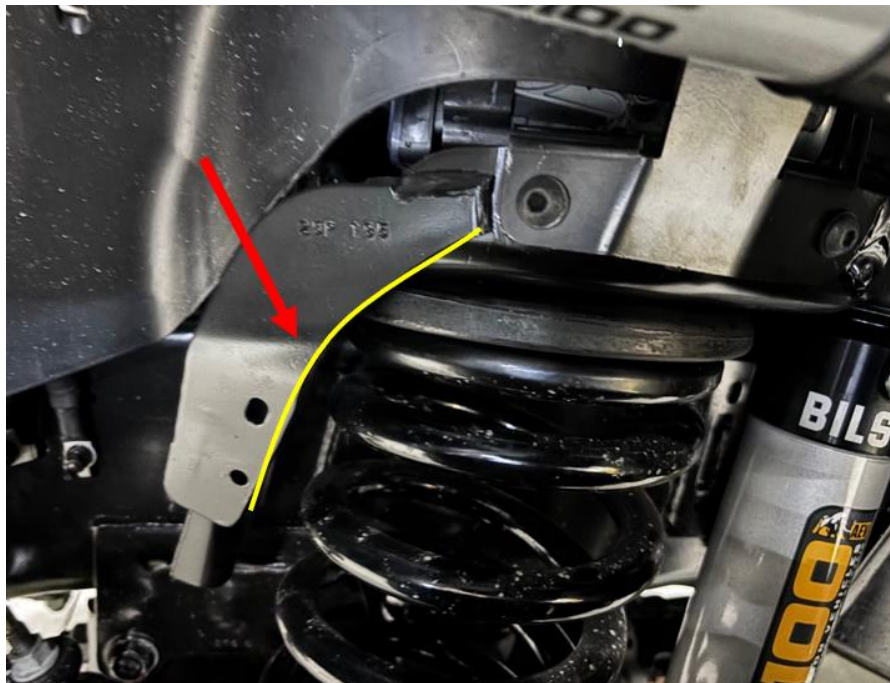

Figure 30



10. Assemble the shock bushings as shown (fig. 31) then install AEV shocks. Torque the lower bolt to 89 lb-ft

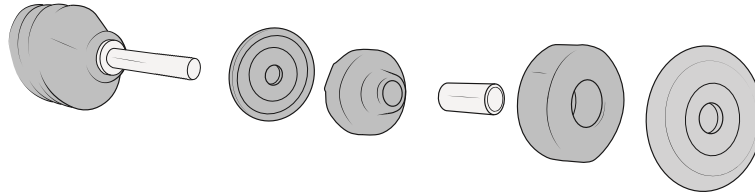

Figure 31

11. Install AEV drive shaft spacer and drive shaft to axle using supplied hardware (fig. 32). Be sure to align using the markings from disassembly. Use blue thread locker and torque to 85 lb-ft

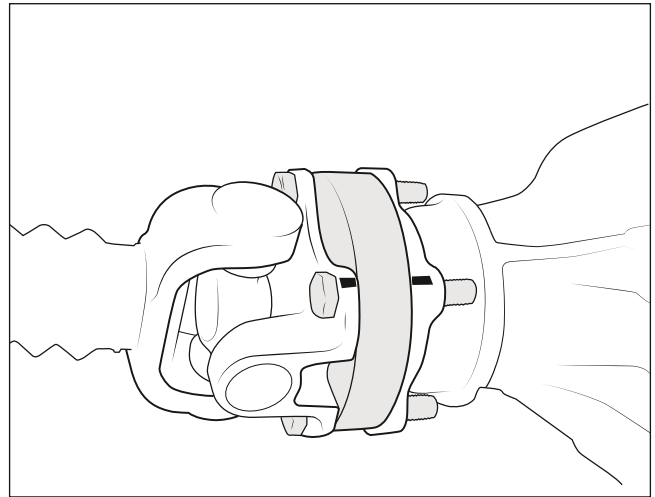
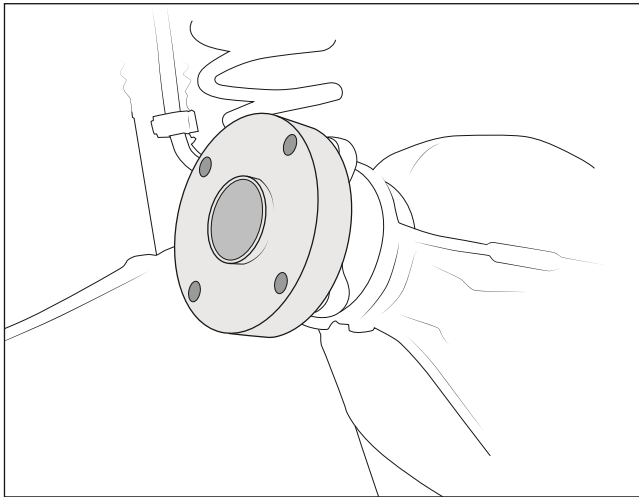

Figure 32

12. Trim the factory soft brake line bracket as shown (fig. 33).
13. Attach the factory soft brake line bracket to the AEV brake line bracket. Use the supplied P-clip to secure the wheel speed sensor wire to the brackets (fig. 33).

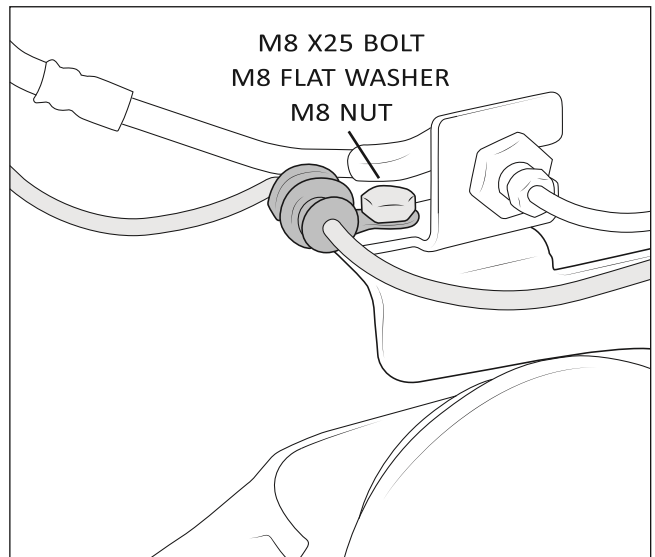
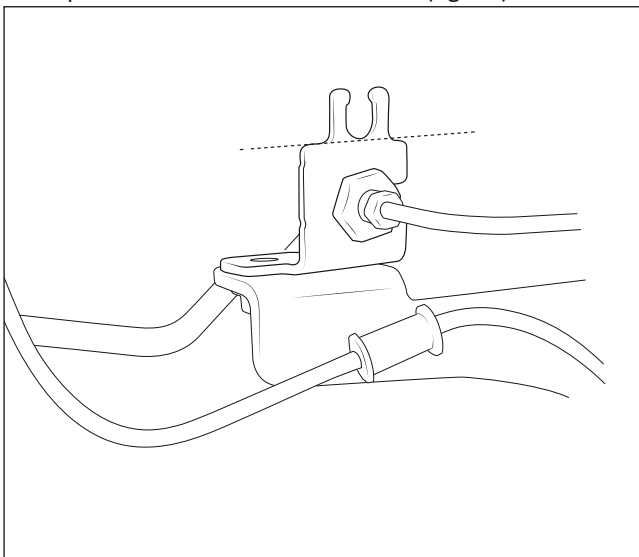

Figure 33



14. Install AEV steel brake lines between the factory flexible lines (fig. 34). NOTE: On POWER WAGON, slight bending of the brake lines may be necessary for proper drive shaft clearance.

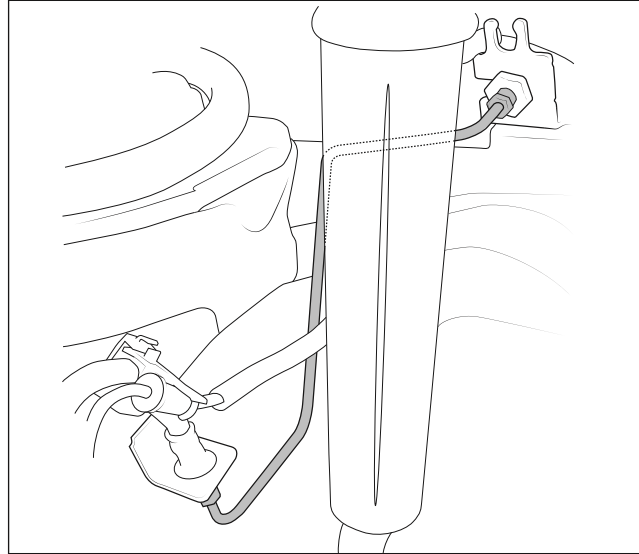

Figure 34

15. Plug the central axle disconnect back in.
16. POWER WAGON ONLY — Plug locker wiring back into axle.
17. Reattach the central axle disconnect and wheel speed sensor wire with zip ties as shown (fig. 35).

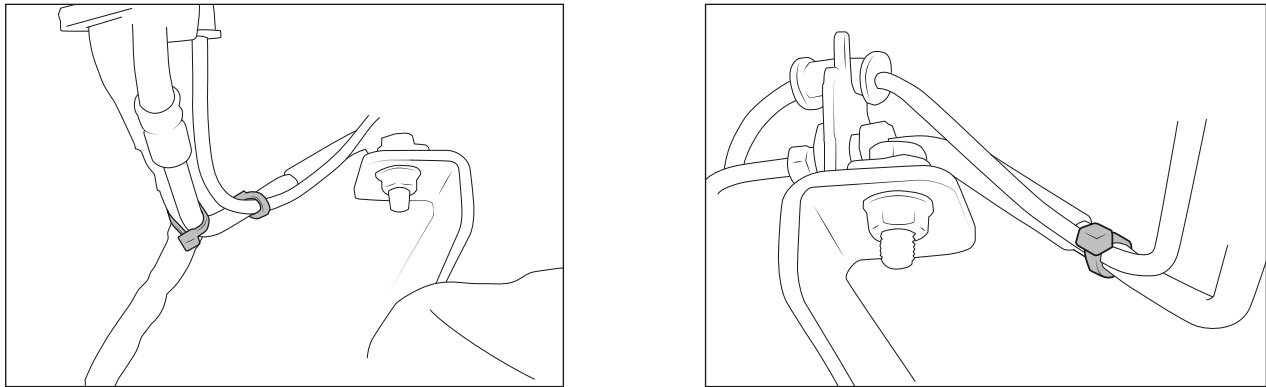

Figure 35

18. Reattach the axle vent hose. Pull slack out of the hose and secure with zip ties as shown (fig. 36).

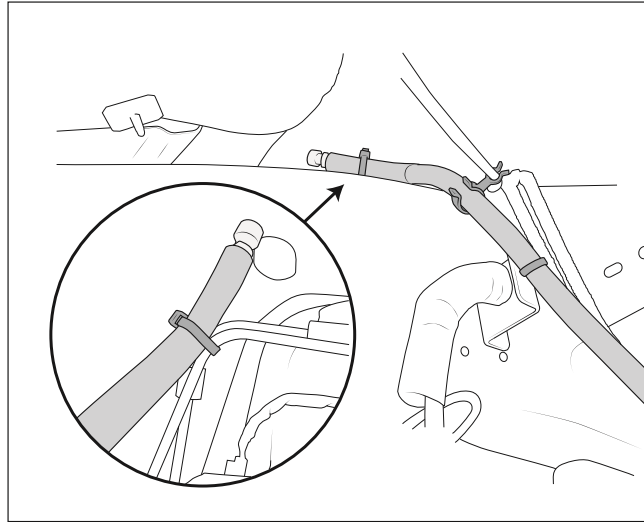

Figure 36

19. Remove the Factory Passenger Side Knuckle and install the supplied AEV Knuckle. Make sure tapered sleeve is fully inserted into machined hole with large end of tapered hole facing upward (fig. 37).

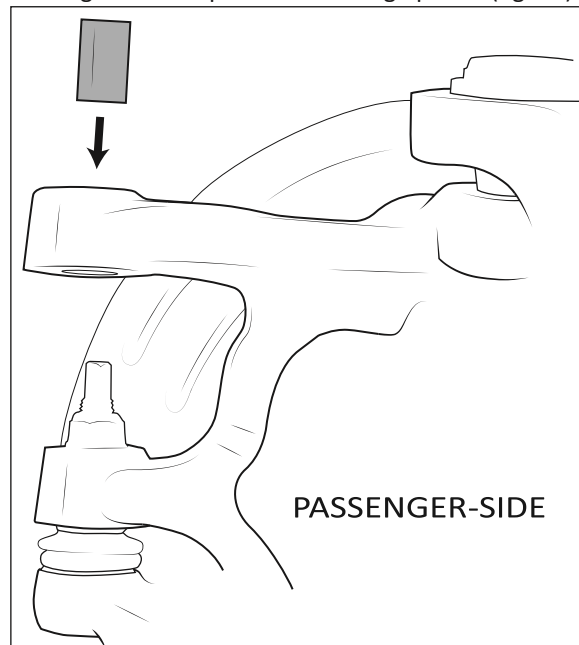

Figure 37

20. Install the draglink. AEV draglink will have the adjuster pre-threaded on in order to protect the clocking collar attached to the bar. Leave the adjuster installed by 3-4 turns and hold up the draglink assembly in vehicle position, and begin threading the adjuster onto the pitman arm TRE and draglink at the same time. Keep both ends aligned/parallel as closely as possible while tightening to prevent cross threading. As the clocking feature engages with the pitman arm TRE, you may feel a slight bind while threading the adjuster. DO NOT FORCE IT. If a bind is felt, lightly rotate the draglink back and forth while tightening the adjuster and once aligned it will easily slip into position and the adjuster can continue to be tightened. Visually make sure both tie rod ends are aligned to one another. If not, back off the adjuster and correct the clocking angle so ends are aligned. Thread the adjuster until the end studs are roughly the same distance apart as measured in step 3A, then proceed to next step. Length doesn't need to be perfect, as this will be set as part of the alignment once the vehicle is on the ground.



! ATTENTION !

IMPORTANT: IMPROPER NUT TORQUE COULD CAUSE STEERING FAILURE. Proper clamp load is critical on the draglink to knuckle interface. The nut **MUST be torqued to 100–110 ft-lb using a torque wrench. Drag link should also be inspected and the nut torque checked after 500 miles and at each oil change. Do not install using an impact gun or a “tight enough” mentality. They must be properly torqued to the specified range using a torque wrench.**

21. Install outer draglink stud into tapered insert on knuckle, install provided nut from the bottom, and torque nut to 100-110ft-lb (fig. 38).

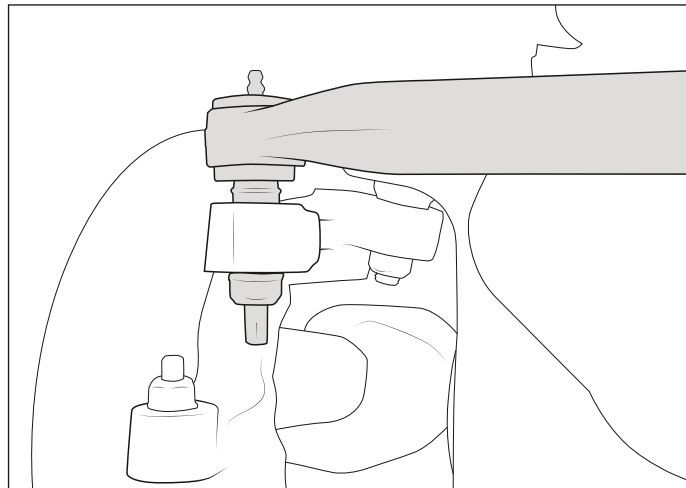

Figure 38

22. Tighten adjuster clamps to 40 ft-lbs (fig. 39). Even if the vehicle is going straight to alignment, do not drive it without the clamps or any steering input could slip the adjuster and compromise the threads.

Note: Recommend re-checking all torques after approximately 500 miles.

Draglink end studs (both ends): 100-110 ft-lb (135-149 N-m) Adjuster clamp nuts (both ends): 40 ft-lb (54 N-m)

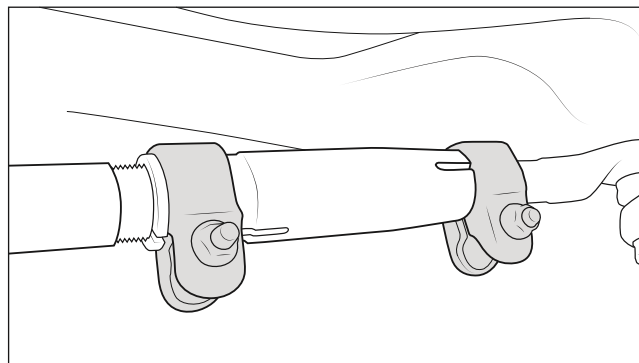

Figure 39



23. Bleed brakes.
24. Install the wheels and tires.

Once the Rear Suspension is completed and the vehicle is on the ground at ride height, you will need to torque the following:

Front radius arm bolts at the frame end — 240 lb-ft

Front track bar bolts — Frame side: 324 lb-ft, Axle side: 285 lb-ft