

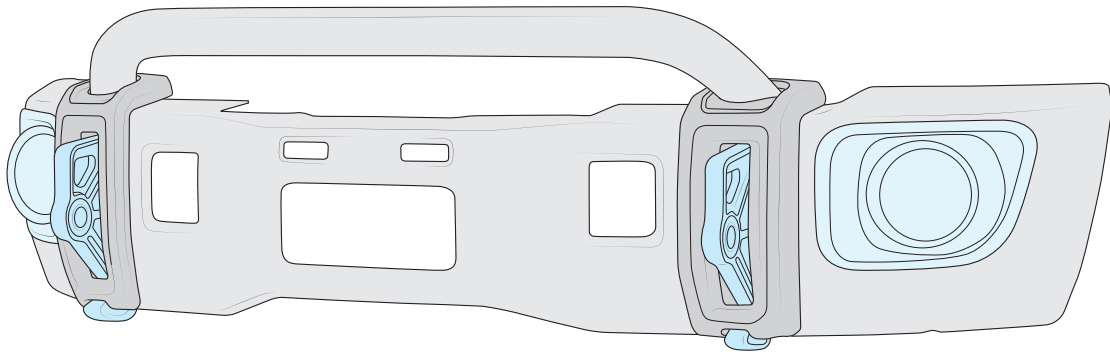

# PREMIUM FRONT BUMPER FOR 2010-18 RAM HD





## **PLEASE READ BEFORE YOU START**

TO GUARANTEE A QUALITY INSTALLATION, WE RECOMMEND READING THESE INSTRUCTIONS THOROUGHLY BEFORE BEGINNING ANY WORK. THESE INSTRUCTIONS ASSUME A CERTAIN AMOUNT OF MECHANICAL ABILITY AND ARE NOT WRITTEN NOR INTENDED FOR SOMEONE NOT FAMILIAR WITH AUTO REPAIR.

<b>INCLUDED PARTS</b>	<b>QTY</b>
Bumper Center Assembly	1
Bumper Corner Kit	1
Bumper Tube Kit	1
Bumper Mounting Kit	1
Fog Light Bezel Kit	1
Winch Mounting Kit	1
Shroud Kit (Gas or Diesel)	1
Tow Hook Brackets (optional)	(1)

## A. REMOVAL OF FACTORY COMPONENTS – SAVE ALL HARDWARE

1. Remove the grill
  - a. Remove the upper shroud by prying the four (six on gas trucks) plastic push pins out (fig. 1).
  - b. Remove the four bolts holding the top of the grill (fig. 2).
  - c. Pull firmly on each side of the grill to separate the plastic retaining clips.
2. On 2014+ GAS trucks, remove the four push pins holding the air dam to the bumper (fig. 3-A).
3. On 2010–2013 trucks Remove the four (4) push pins attaching the cooling shroud to the radiator (fig. 3-B).

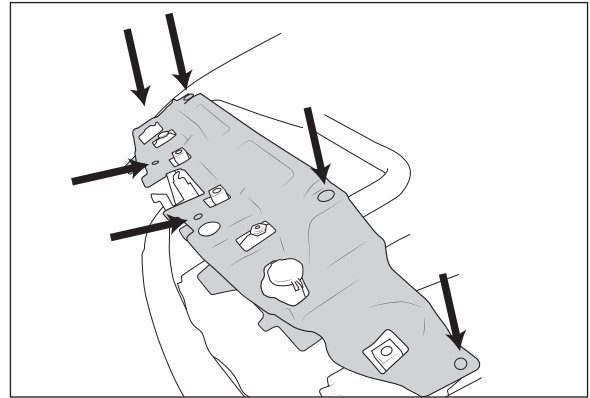
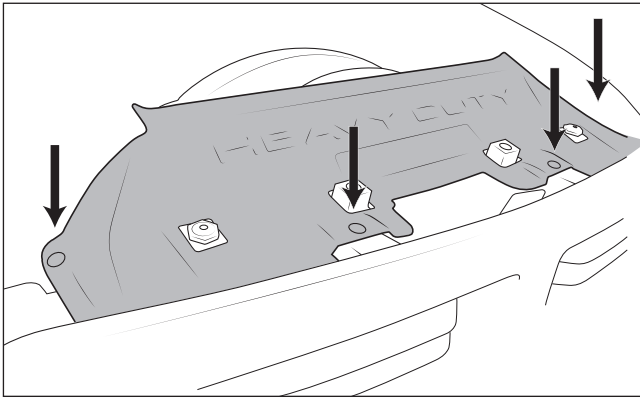

Figure 1 - Left: Diesel, Right: Gas

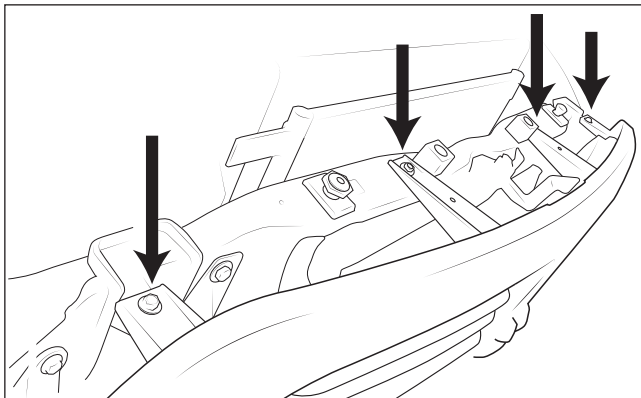

Figure 2

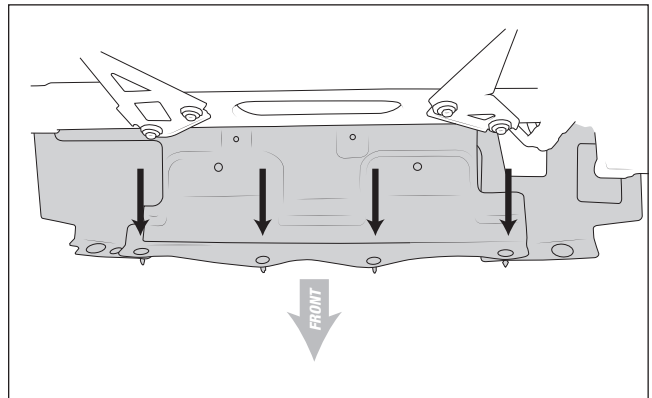

Figure 3-A

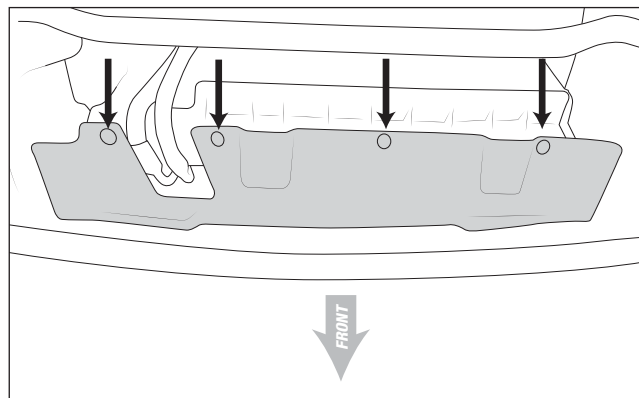

Figure 3-B

4. Disconnect the bumper harness at the connector on the left side of the bumper (fig. 4).
5. Disconnect the Front Park Assist (if equipped). Remove and SAVE sensors and bezels.
6. Disconnect the block heater plug from the bumper (if equipped)(fig. 5).

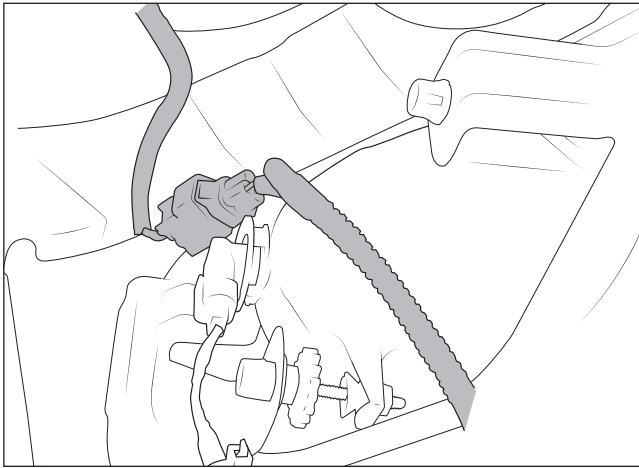

Figure 4

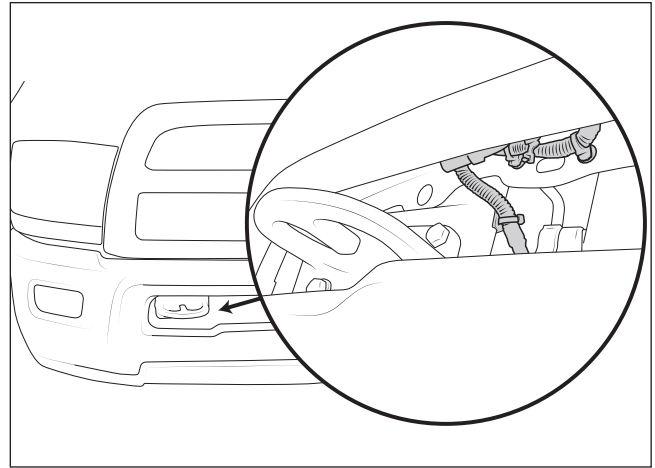

Figure 5

7. Remove the 8 nuts (4 each side) and the tow hook bolts (if equipped) to remove the bumper (fig. 6).

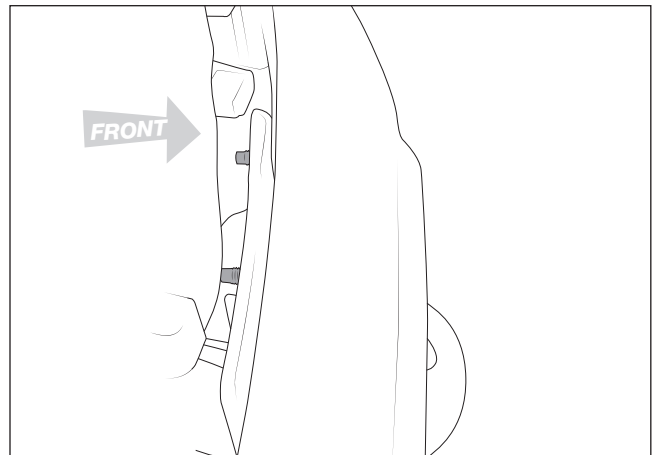
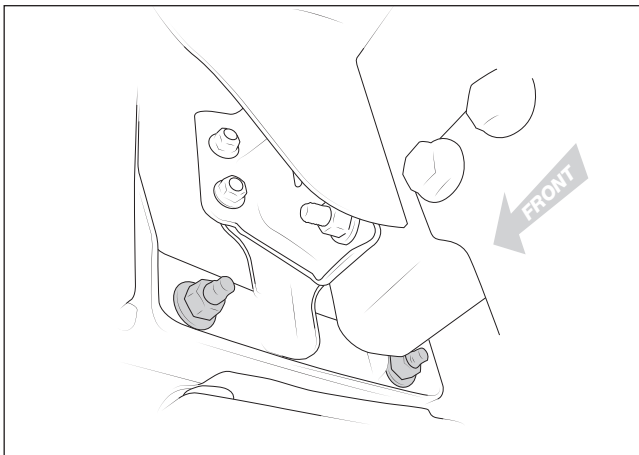

Figure 6 Left: Lower bolts shown from behind Right: Upper bolts shown from above

8. Retain the factory fog lights and bumper harness if reusing the factory fog lights.
9. Remove compatibility hardware on both sides if equipped (fig. 7).

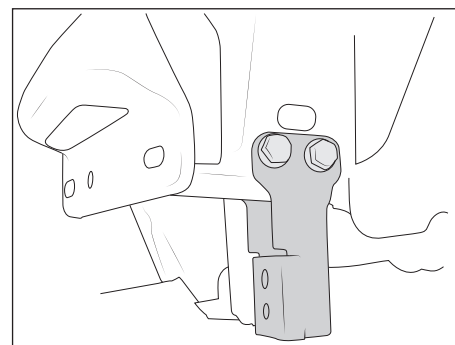

Figure 7

10. On 2010–2013 Diesel trucks remove the remaining bumper brackets by loosening the nuts on the bolt plates and using a reciprocating saw to cut the bolts (fig. 8).

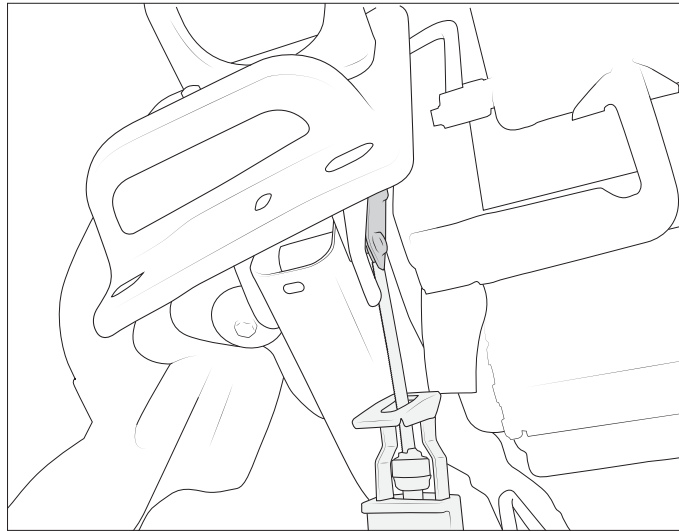

Figure 8

11. Retain the factory tow hook brackets if equipped (fig. 9)

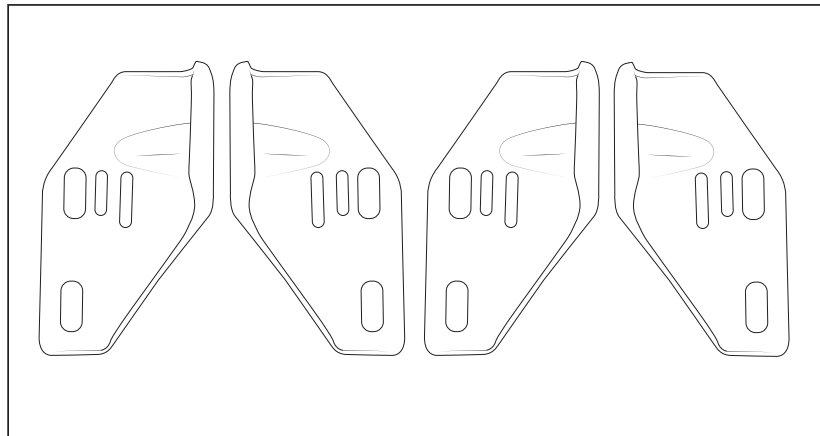
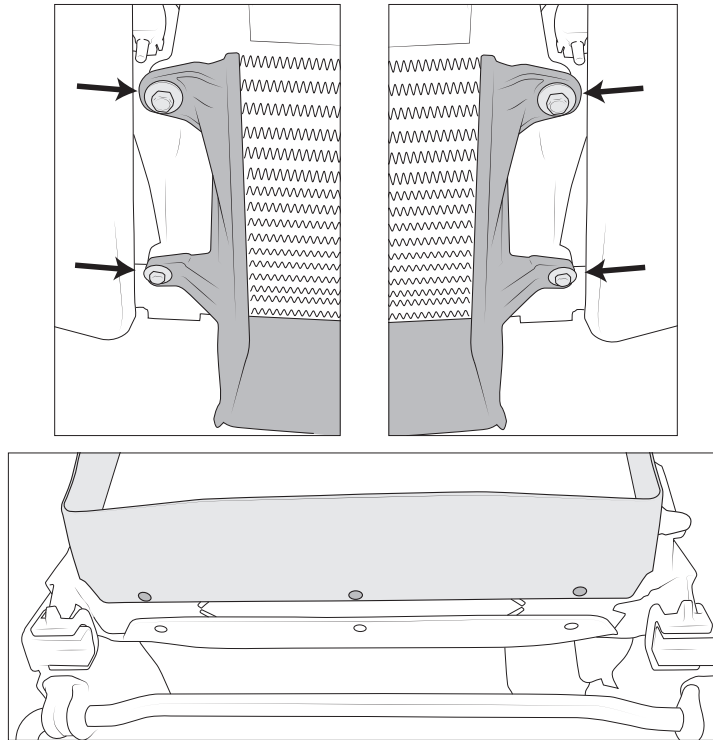

Figure 9

**2014+ DIESEL TRUCKS ONLY. GAS TRUCKS and 2010–2013 DIESEL TRUCKS SKIP TO STEP 16.**

- 12. Loosen the bolts holding the bumper brackets to the frame.
- 13. Remove the front intercooler shroud and save hardware (fig. 10)



*Figure 10*

- 14. Remove the intercooler hoses at the intercooler.
- 15. Remove the intercooler bolts (fig. 11).

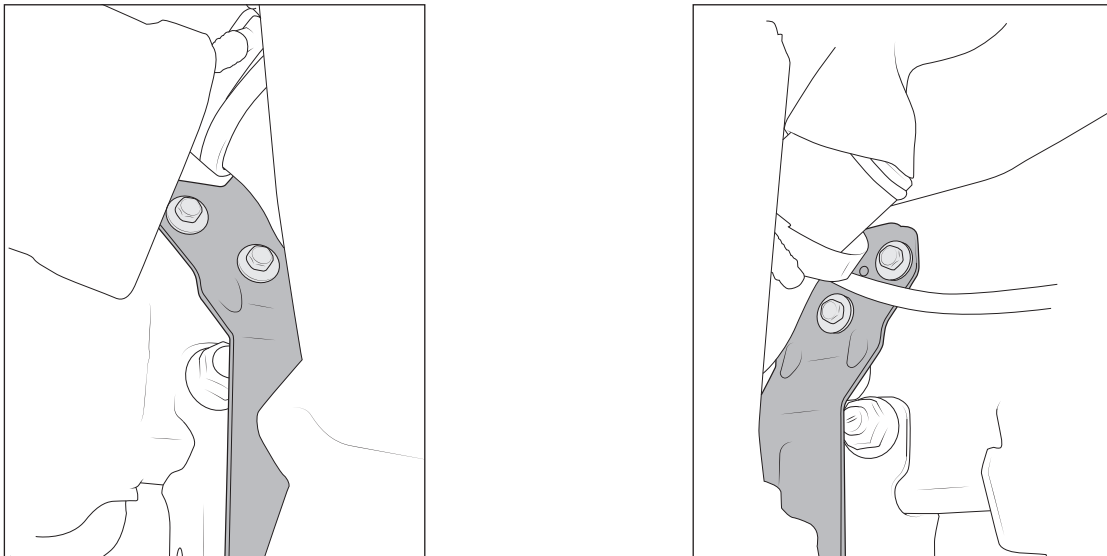

*Figure 11*

16. Remove the intercooler.
17. Remove the remaining bumper brackets and **save hardware** (fig. 12).
18. POWER WAGON – Remove winch and winch mounting brackets.

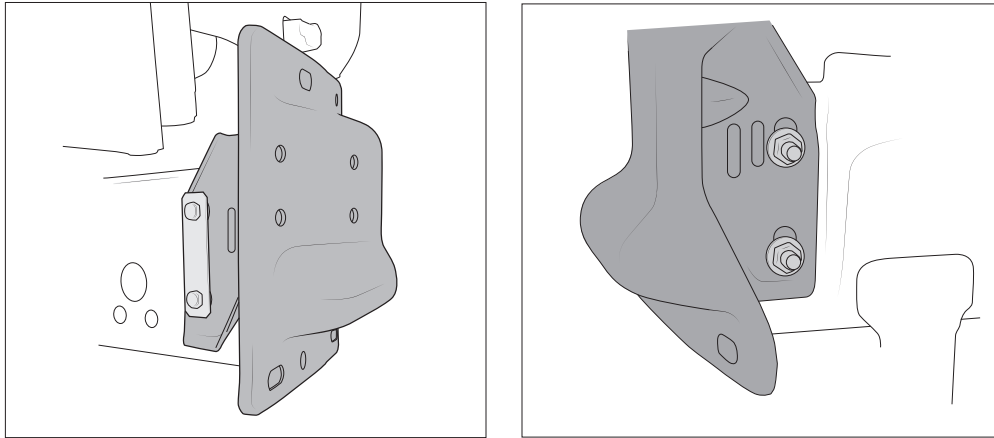

Figure 12

19. Retain the factory tow hook brackets if equipped (see fig. 9)
20. **For 2014+ GAS trucks**, trim the lower radiator shroud as shown (fig. 13).

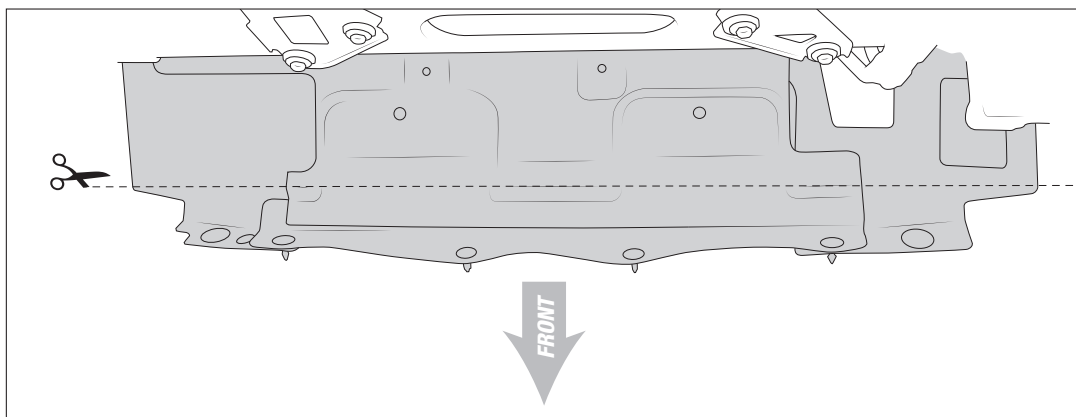

Figure 13

## B. PREPARE AEV BUMPER FOR INSTALLATION

1. Install the inner and outer frame brackets with the factory tow hook brackets as shown below depending on the mounting kit purchased for your specific application.

NOTE: 5500 and vehicles not equipped with factory tow hooks you will need additional AEV brackets PN:10308013AA.

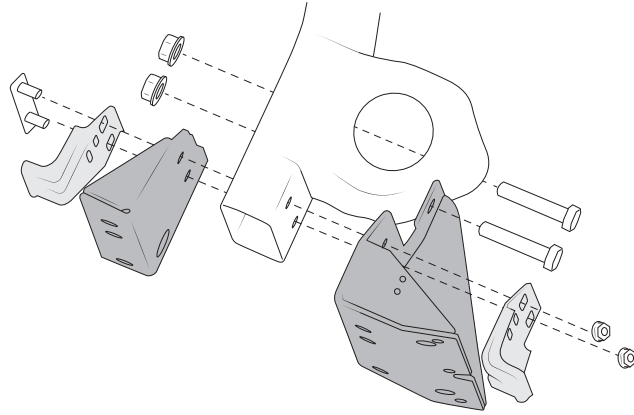

Figure 14-A: With Factory Compatibility Beam and Hardware (Left Side)  
Kit: 10308002

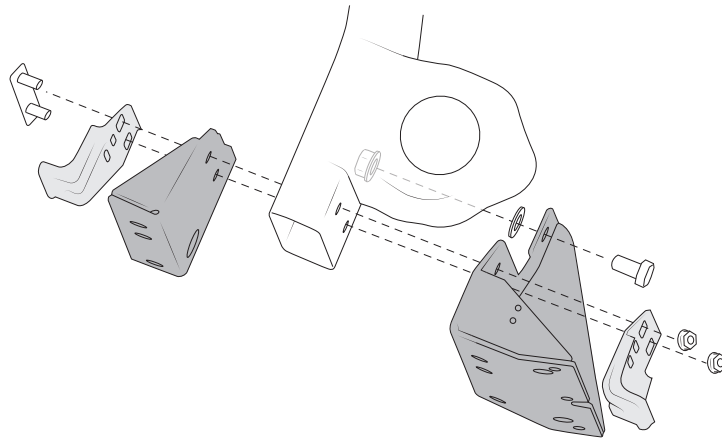

Figure 14-B: Existing Frame Hole With No Compatibility Beam (Left Side)  
Kit: 10308002

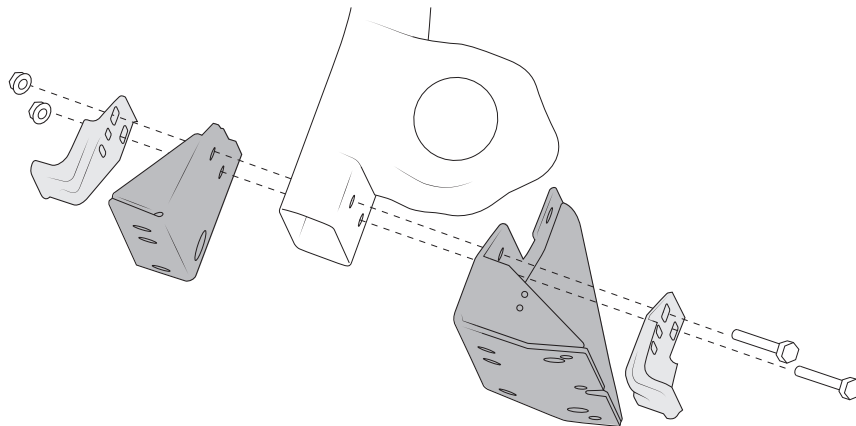

Figure 14-C: No Frame Holes and No Compatibility Beam (Left Side)  
Kits: 10308002 + AEV99084

2. 2014+ DIESEL TRUCKS Re-install the diesel intercooler. LEAVE LOOSE at this time.
3. Re-install the compatibility hardware if equipped (see fig. 7) and LEAVE LOOSE at this time.
4. Place the bumper center section on a protected surface.
5. If installing a Warn 16.5 winch, install the winch and fairlead using fasteners provided in the winch kit. Torque as instructed by the winch manufacturer. Use the AEV provided spacers (PN: 10308012) between winch and bumper (fig. 15). **NOTE: For Warn M12000 or M15000 winches see Appendix A. For Power Wagon winches see Appendix B.**

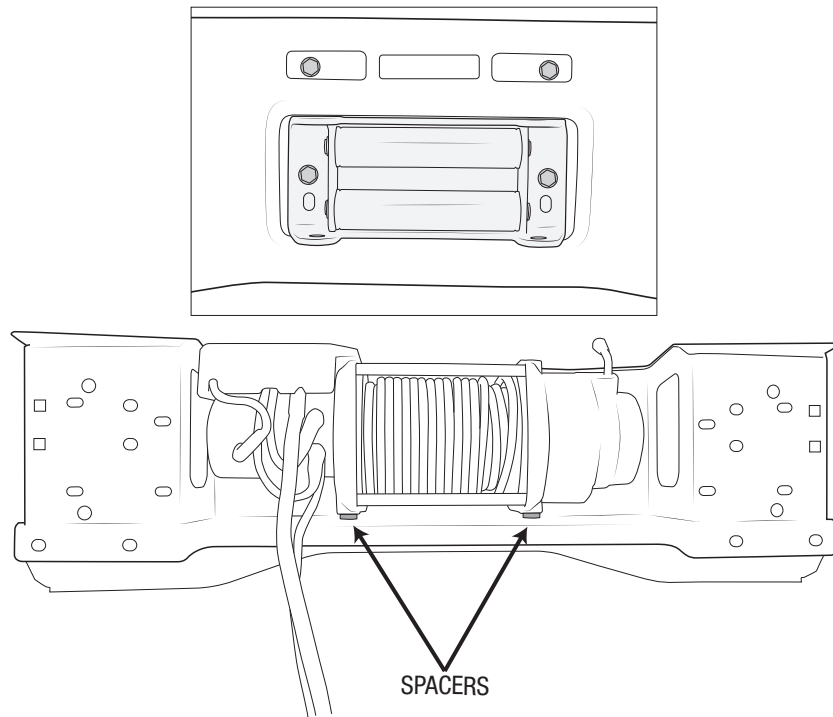

Figure 15

6. Install two (2) M12 x 35 carriage bolts in the upper-outside corners of bumper and secure with push nuts (fig. 16).

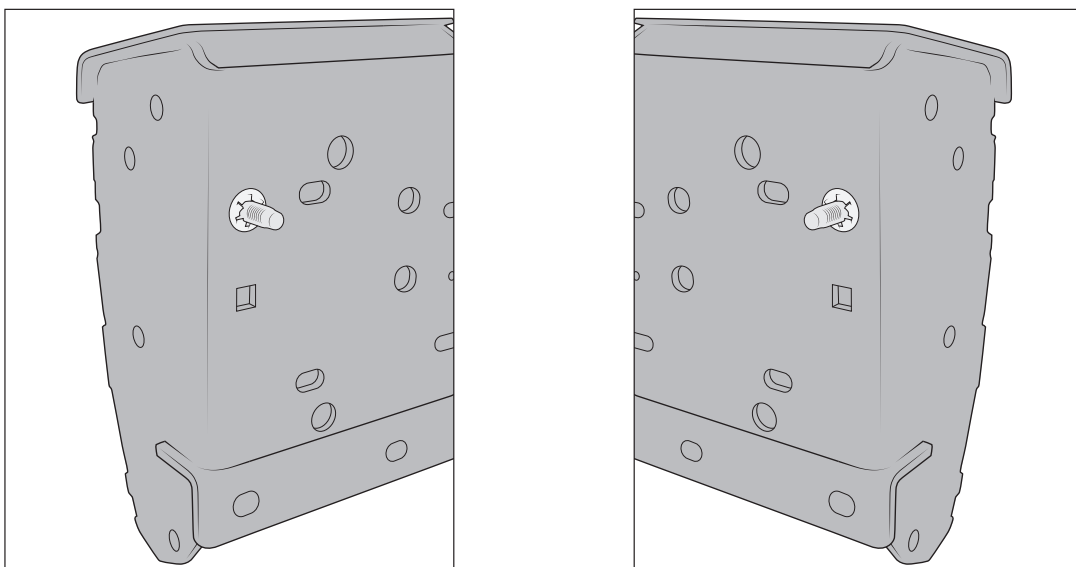

Figure 16

## C INSTALL BUMPER CENTER SECTION

1. With a helper, lift bumper into position inserting carriage bolts from the previous step through the upper holes in the outer frame mounting brackets (fig. 17).
2. Thread two (2) M12 nuts onto the bolts going through the frame brackets to secure the bumper.

NOTE: The use of a floor jack (if working on the ground) or a trans jack (if working on a hoist) to assist in positioning the bumper is recommended.

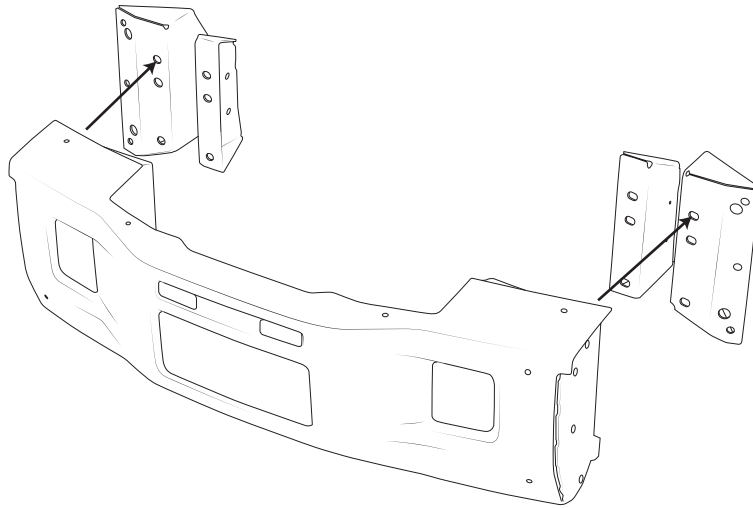

Figure 17

3. Install the remaining ten (10) bolts and hand tighten. There should now be six (6) bolts in each side of the bumper (fig. 18).

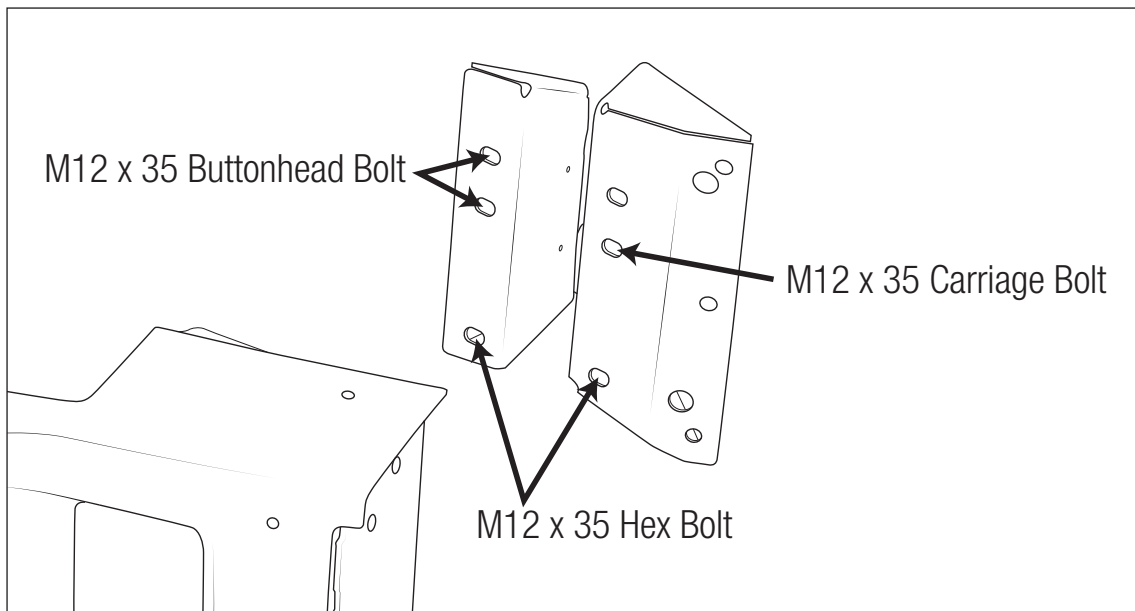

Figure 18

## D INSTALL BUMPER TOW LOOPS AND CORNERS

1. Assemble the tow loops and bumper corners with M12 x 60 carriage bolts and push nuts as shown (fig. 19). **NOTE: Start ALL of the bolts through the corner and tow loop before putting the push nuts on.**

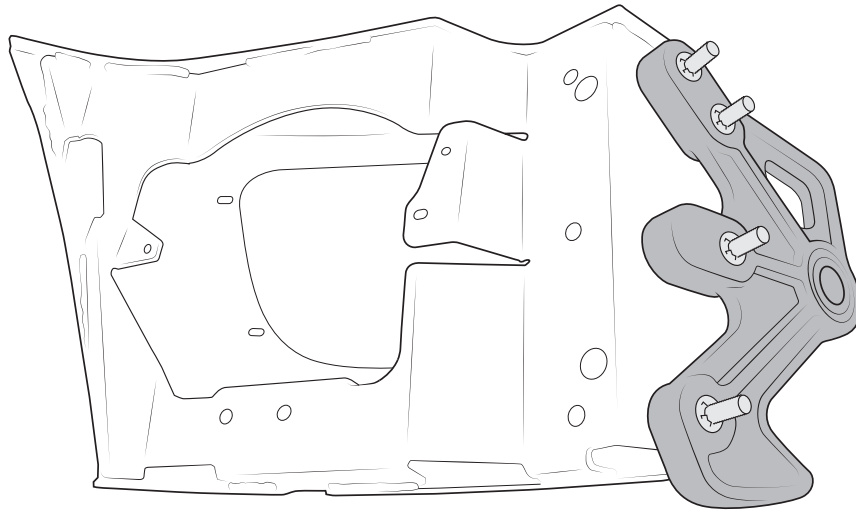

Figure 19

2. Lift the corner assembly onto the bumper center section inserting the four bolts from previous step into the corresponding holes on the bumper center section (fig. 20). Secure with M12 nuts and hand tighten.

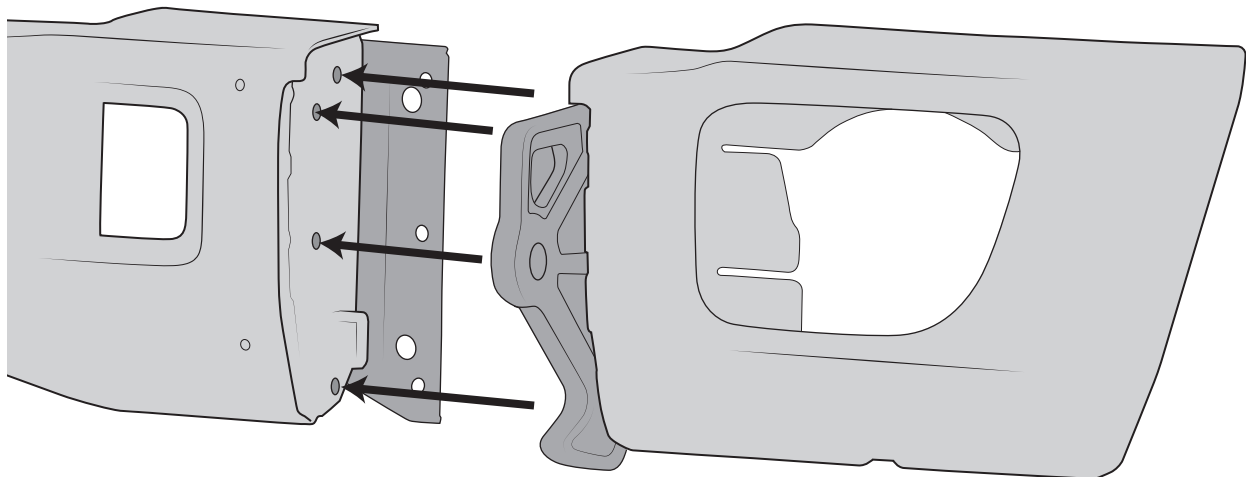

Figure 20

3. Insert three (3) M12 x 35 carriage bolts into the bumper corner and through the holes in the outer frame bracket (fig. 21). Secure with M12 nuts and hand tighten.

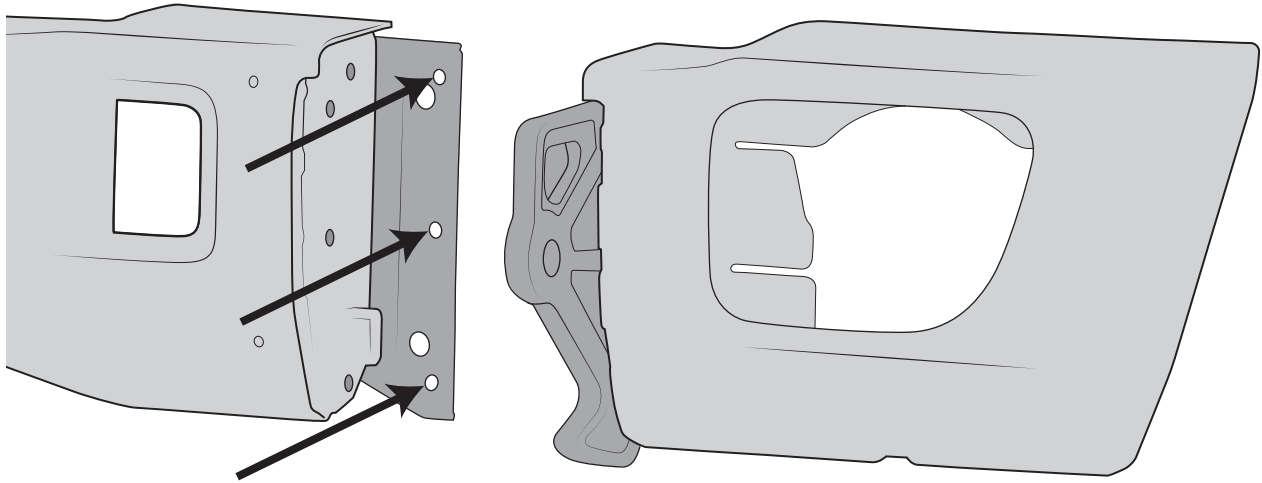

Figure 21

4. Repeat these steps for the opposite side.

## E ADJUST, ALIGN, AND TORQUE

1. Before installing the tow loop bezels and tube, the bumper must be adjusted and all bolts tightened

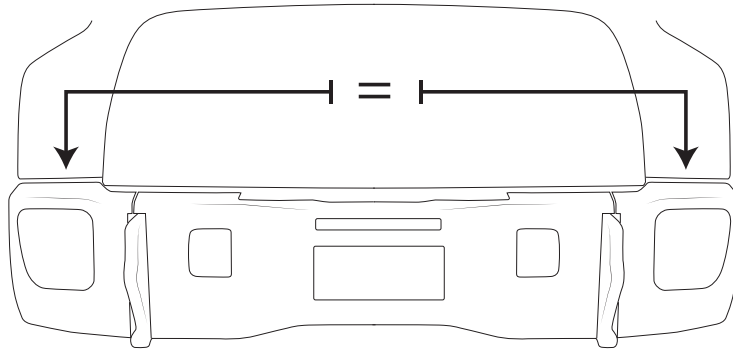

Figure 22

2. Tighten all hardware in order: Center section to brackets, Brackets to frame, Corners to center section.  
**NOTE: When tightening the corners, tighten the tow hook bolts first. Torque ALL bolts to 70 lb-ft. Torque compatibility hardware to 172 lb-ft.**

Figure 25

7. **2010–2013 trucks**—Install the AEV cooling shroud bracket to the bumper using the supplied 3/8" x 1" hardware (fig. 26). Make sure the bolts going through the winch mount are located so as not to interfere with the winch. **NOTE:** If the winch hardware is already using the front set of slots you can use this hardware to secure the cooling shroud bracket.

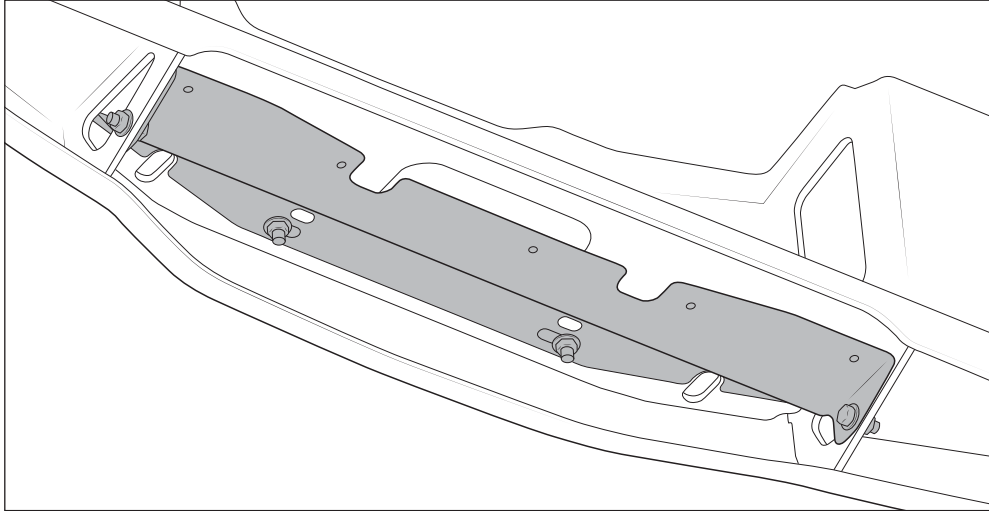

Figure 26

8. **2010–2013 trucks**—Re-install the factory cooling shroud to the AEV bracket and back to the radiator using the factory push pins.
9. **DIESEL trucks continue to section F**, for 2014+ GAS trucks, install the air dam bracket to the bumper using the supplied hardware (fig. 27). Torque to **9 lb-ft**.

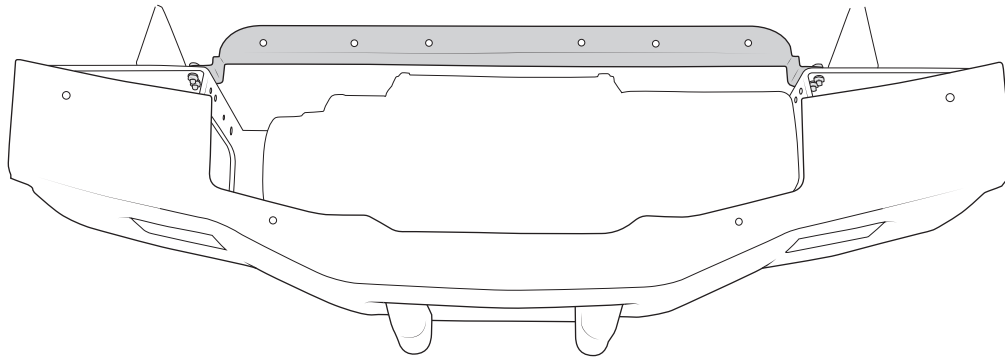

Figure 27

10. Drill UP through the bracket into the plastic air dam (fig. 28).

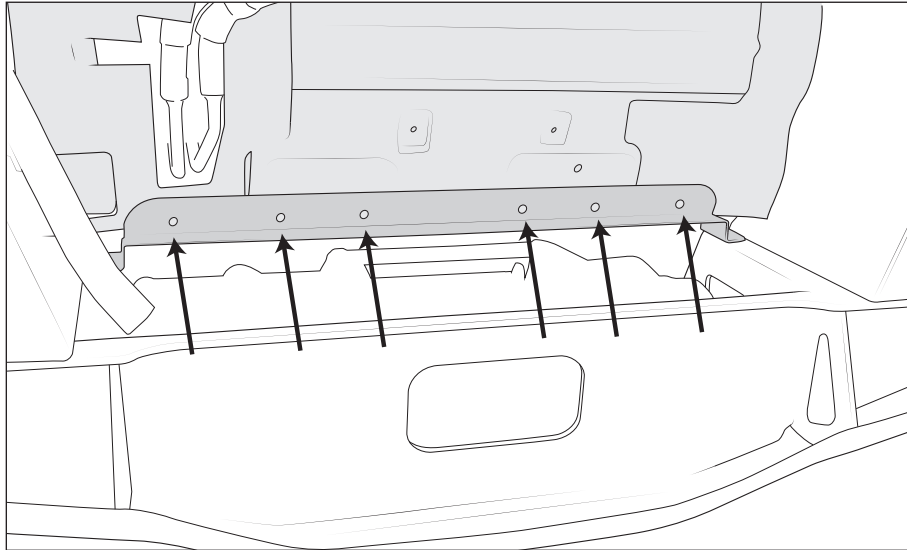

Figure 28

11. Install push pins securing the air dam to the bracket (fig. 29).

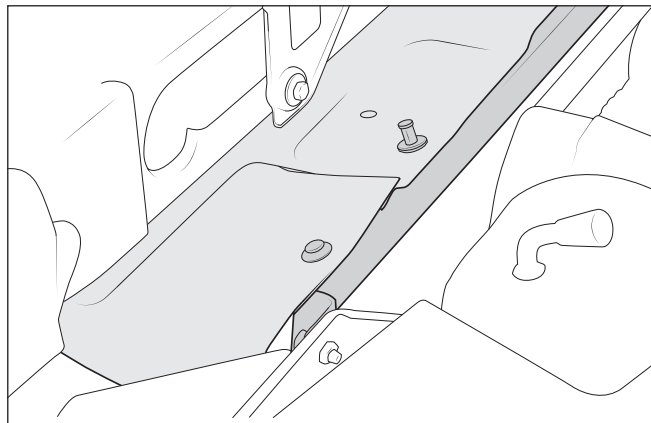

Figure 29

## F INSTALL FRONT PARK ASSIST SENSORS (IF APPLICABLE)

NOTE: If the factory sensor bezels are not black, you may paint them or purchase black bezels from Mopar. Outboard bezels (M-5VS87ZZAA). Inboard bezels (M-5VS88ZZAA).

1. Clean bezel with alcohol then install appropriate bezel (IB to center section, OB to corners) into each bumper hole using black RTV between bezel and bumper (fig 30).

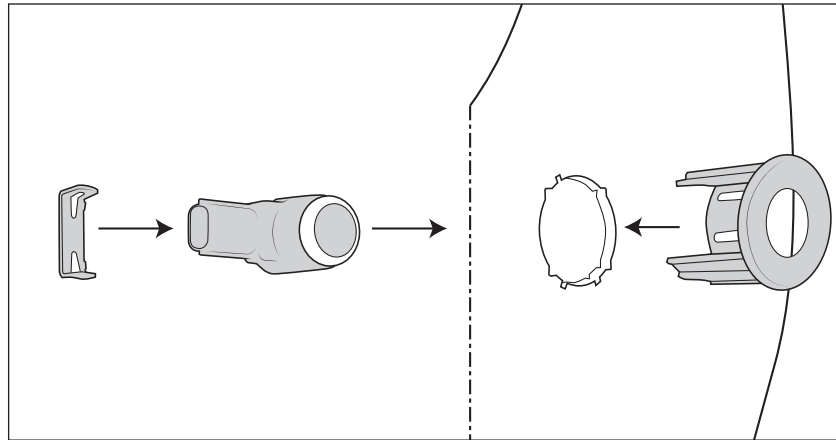

Figure 30

2. Install sensors into the bezels from the back side. Note the orientation of the sensors, the connector end should point in the directions shown (fig.31).

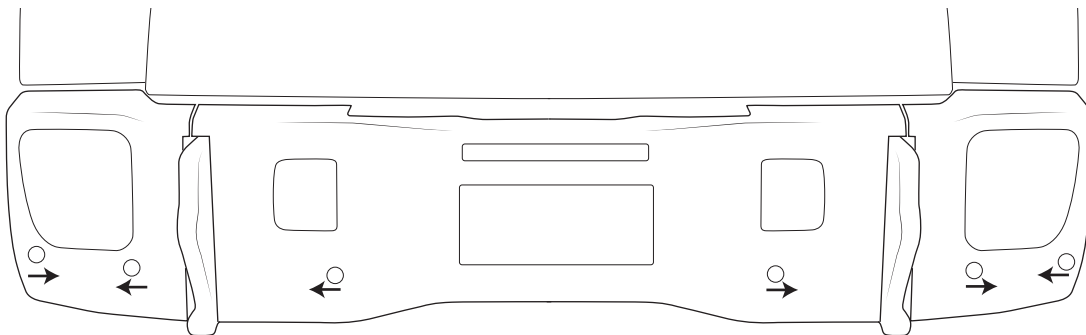

Figure 31

3. Install locking clip onto back of bezel (fig. 32).

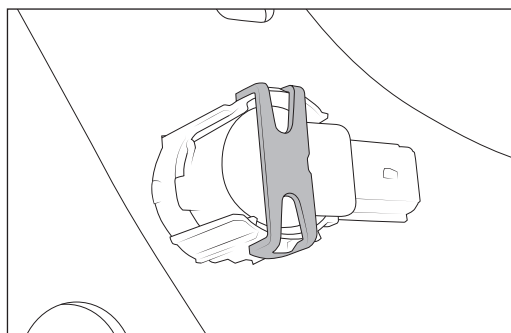

Figure 32

4. The wiring harness for the sensors will need to be lengthened. You may choose to do this yourself or purchase a new harness from AEV (PN: AEV30301049)

## G INSTALL TOW LOOP BEZELS AND TUBE

1. Install one side tow loop bezel with M6 x 20 bolts and washers (fig. 33). Hand tighten.
2. Slide the second bezel onto the end of the tube, then position together in place on the bumper (fig 34).

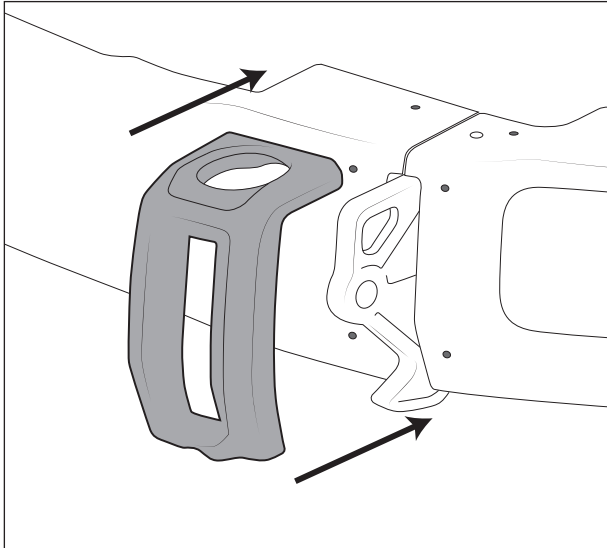
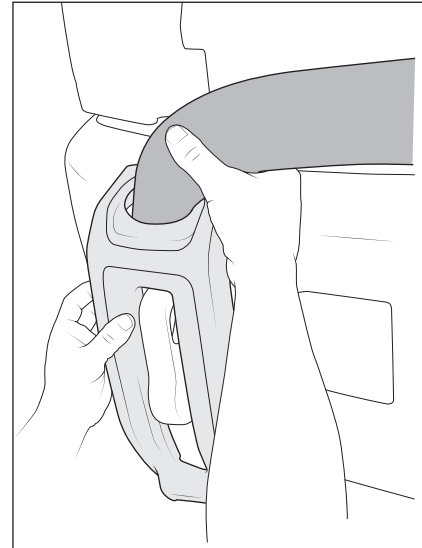

Figure 33



4

3. Install the M10 x 25 button head bolts and washers to tube hand tight (fig. 35).
4. Fasten the second tow loop bezel and tighten both bezels to **9lb-ft**.
5. Tighten tube to **30 lb-ft**.
6. Attach the block heater wiring to the bumper as shown (fig.36).
7. Re-install the grill.

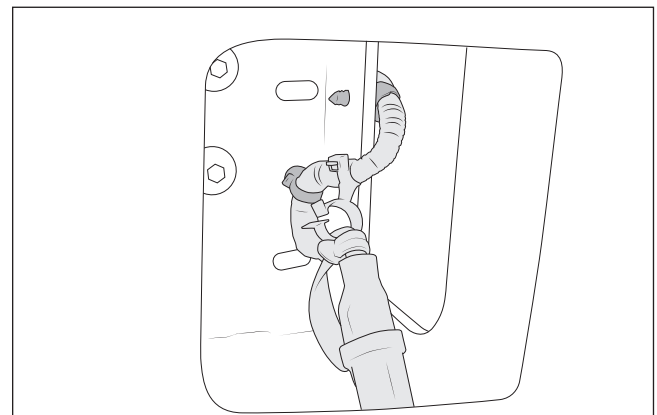
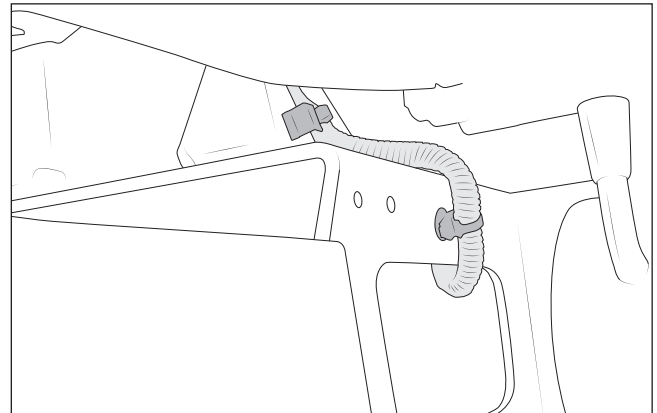

Figure 36

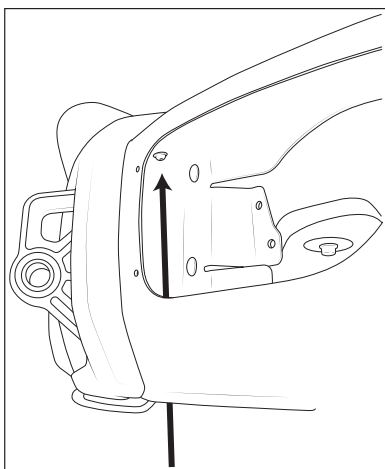

Figure 35

## H INSTALL LAMPS

There are three options available for in-bumper lighting. Follow the steps for the option you chose. If you are not installing lamps skip to section H.

### USING FACTORY FOG LAMPS

1. Install the supplied M6 U-nuts onto bumper corners (fig. 37).

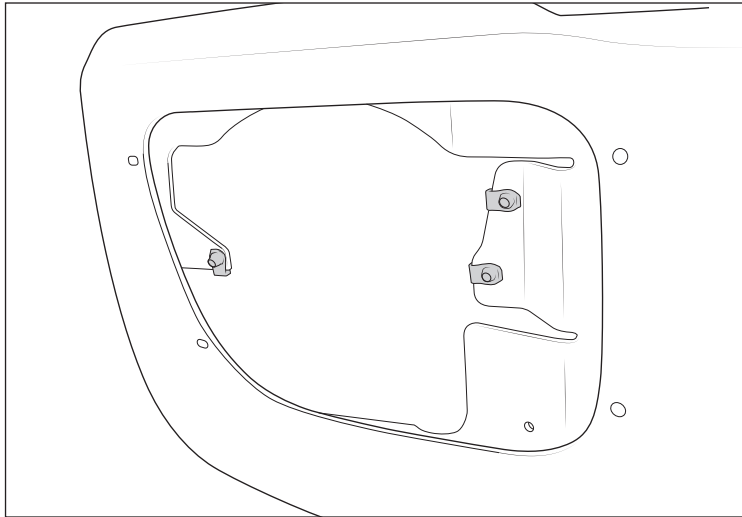

Figure 37

2. Install factory fog lights into bumper corners with factory hardware (fig 38). Torque to **9 lb-ft**.

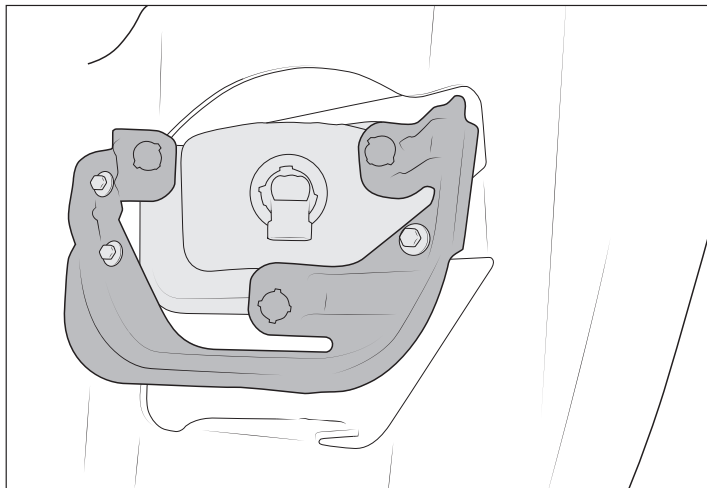

Figure 38

3. Install factory bumper harness into bumper as shown (fig. 39).

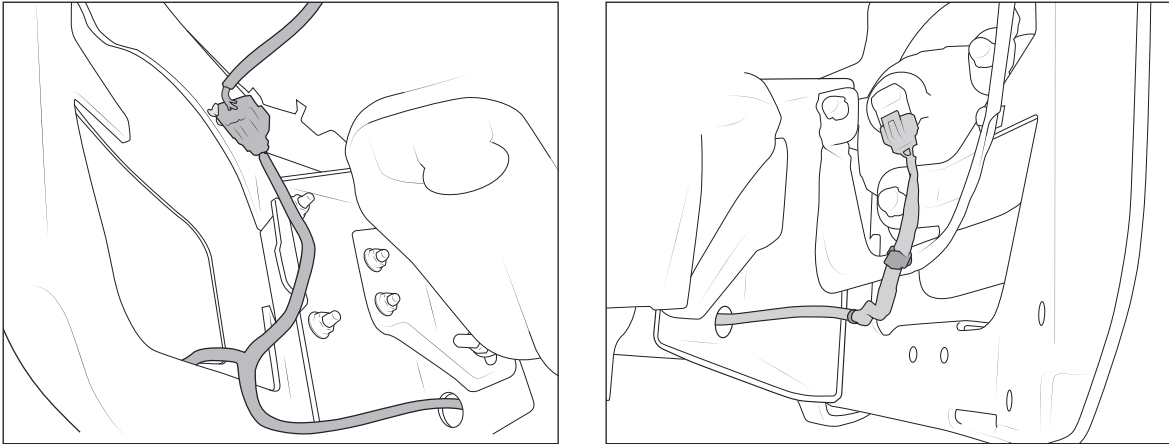

Figure 39-A

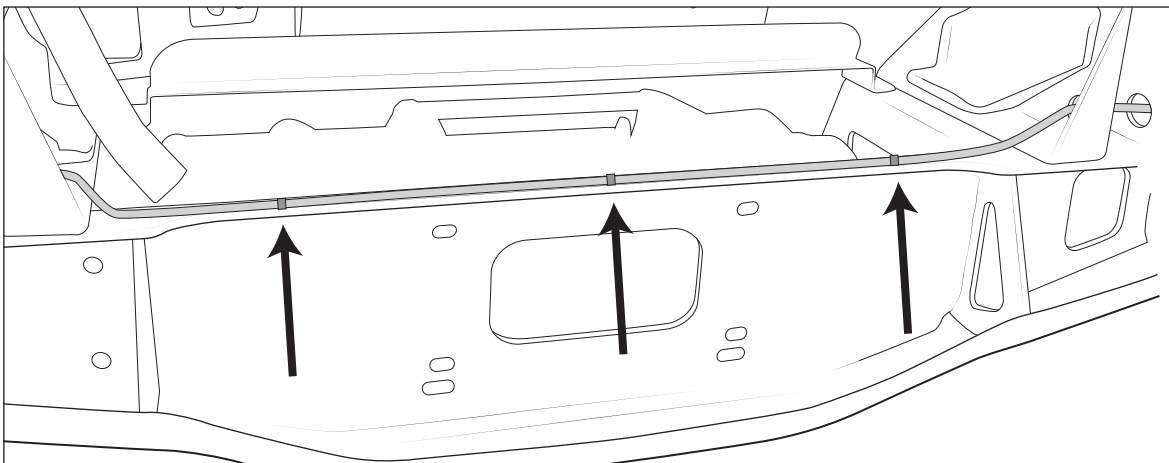

Figure 39-B: Zip tie wiring harness to bumper

### USING VISION X TUNGSTEN 6510 LAMPS

1. Install AEV light brackets to bumper corners with supplied hardware (fig. 40).

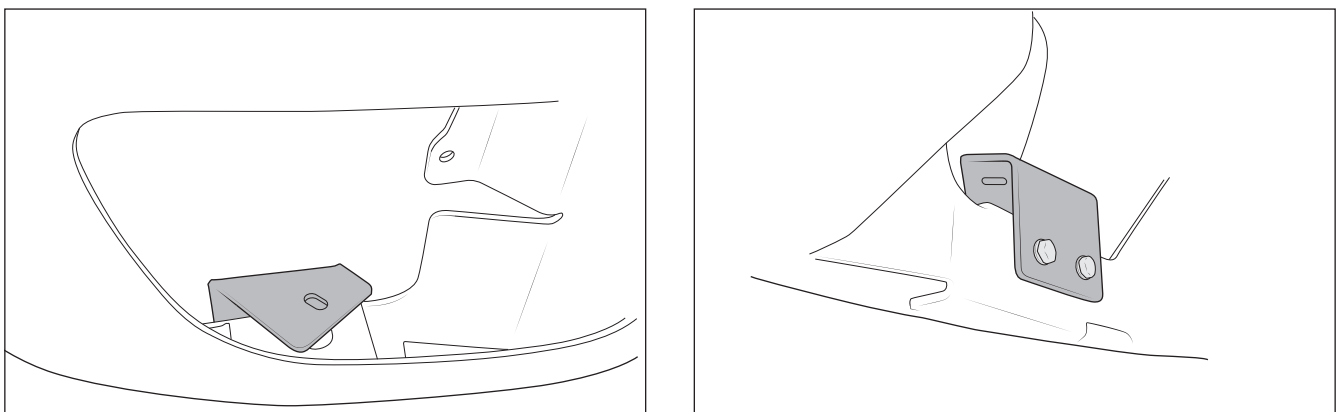

Figure 40

2. Install Vision X lamps hand tight with new supplied M10 nuts.
3. Use the wiring harness and switch included with the Vision X lamps.
4. Aim the lights and tighten all the bolts on the lights. Torque the M8 bolts to **18 lb-ft.**

## USING VISION X ANNON LED LAMPS

1. Install AEV light brackets to bumper corners with supplied hardware (fig. 41).

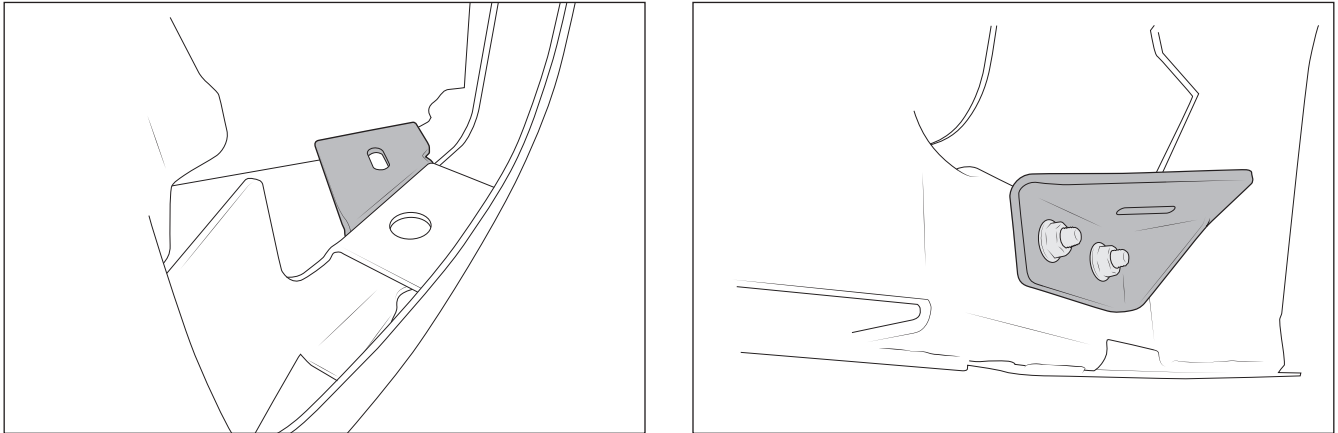

Figure 41

2. Install Vision X lamps with the hand tight.
3. Use the wiring harness and switch included with the Vision X lamps.
4. Aim the lights and tighten all the bolts on the lights. Torque the M8 bolts to **18 lb-ft**.

## I INSTALL LAMP BEZELS

NOTE: Hold the light bezel up and make sure it doesn't interfere with the light before installing the bezel. Adjust the light as necessary.

1. Clean the backside of the Lamp Bezels with alcohol. Apply approximately 3" long beads of black RTV at all four corners of the bezels (fig. 42).

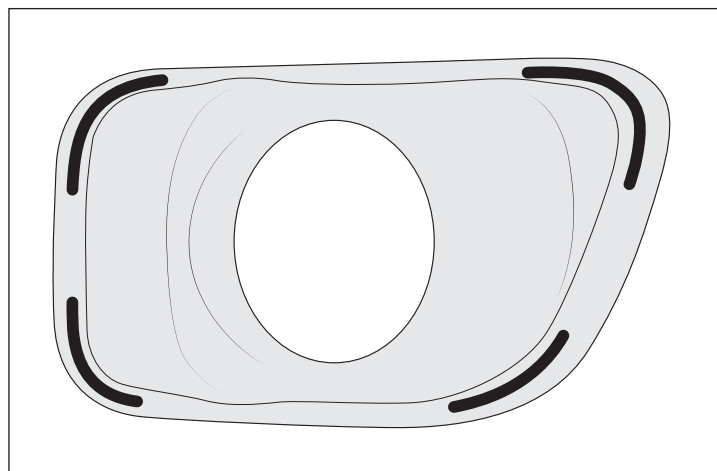

Figure 42

- Carefully position the bezels on the bumper and press firmly. Use several strips of painter's tape to hold the bezel in place until the RTV cures (fig. 43).

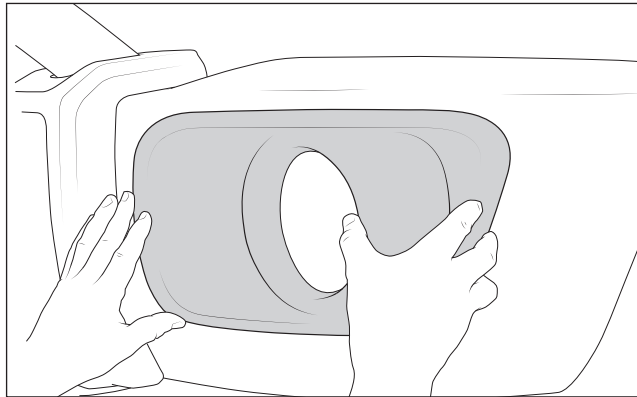

Figure 43

- Trim the front edge of both inner fender liners to provide approximately 1/2" gap between the liner and the bumper corner (fig. 44).
- Install fender liner retainer plates (fig. 45).

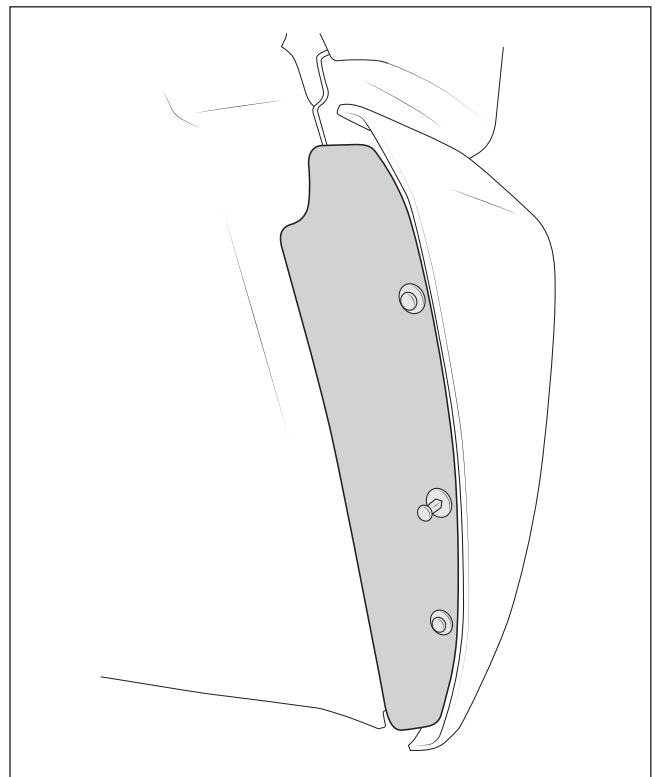
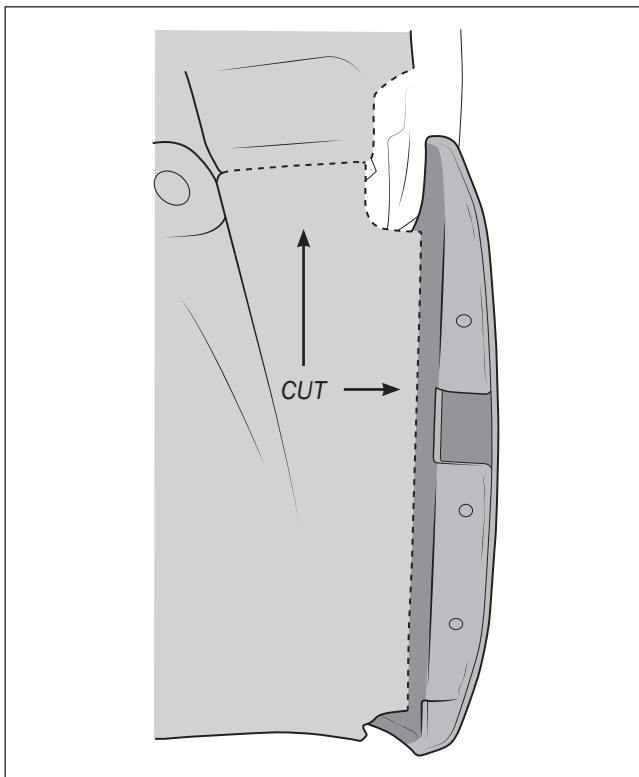

Figure 44

## J INSTALL 2014+ DIESEL INTERCOOLER SHROUD

1. Install edge guard onto the left side of the intercooler shroud to protect winch wiring (fig. 46).

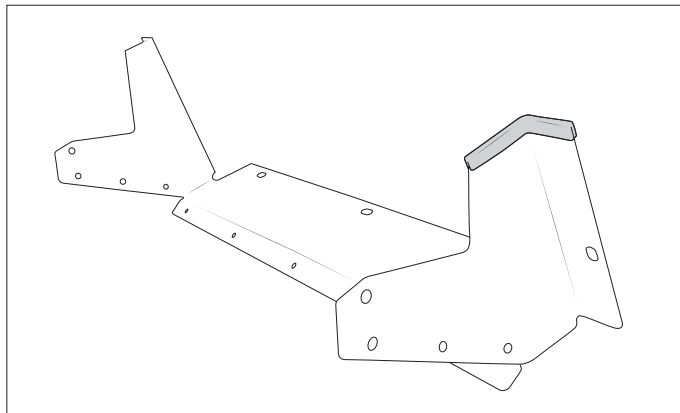

Figure 46

2. Attach AEV intercooler shroud to intercooler at the two lower factory locations using the factory hardware (fig. 47). Use the three factory push pins so secure the shroud along the bottom of the intercooler.

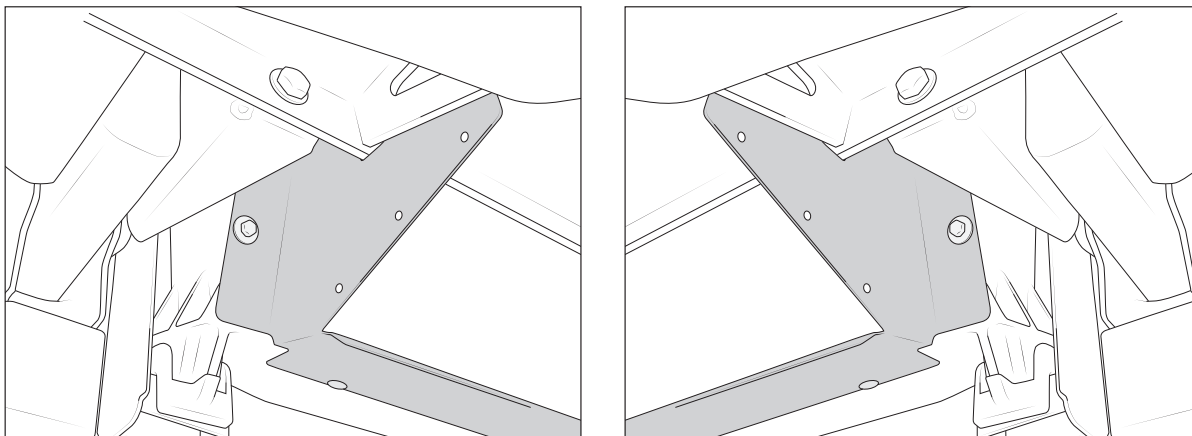

Figure 47

3. To attach the sides of the intercooler shroud to the bumper, use the upper shroud hole as a guide to drill out the bumper and secure with supplied M6 x 20 bolts, nuts, and washers. **Torque to 9 lb-ft.** (fig. 48).

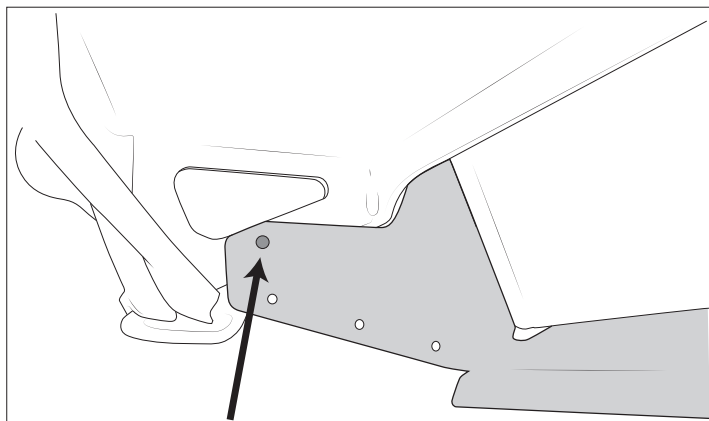
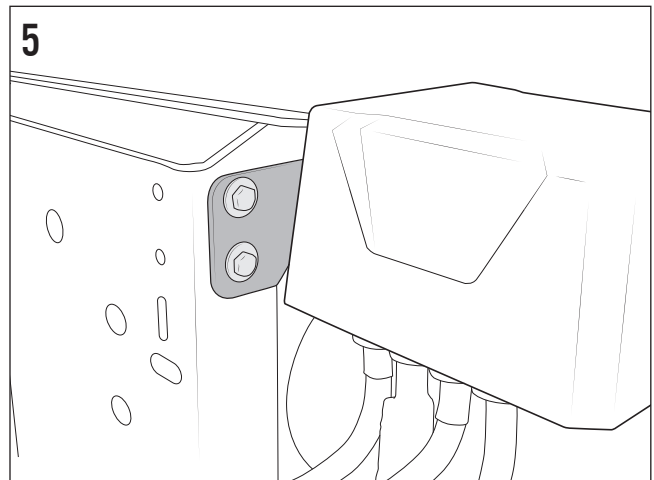
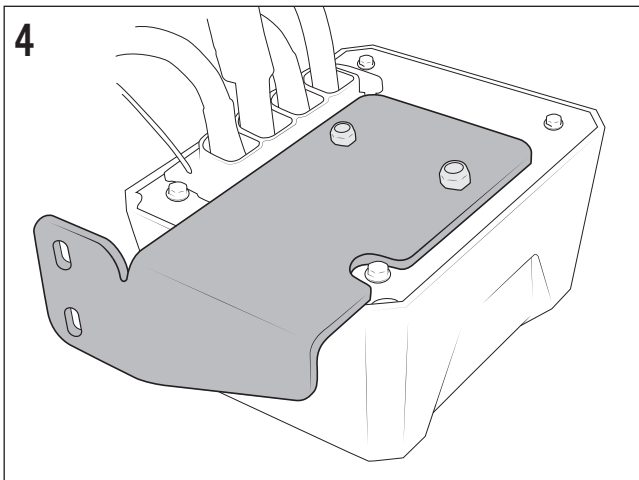
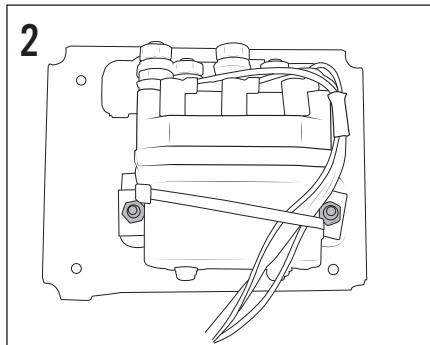
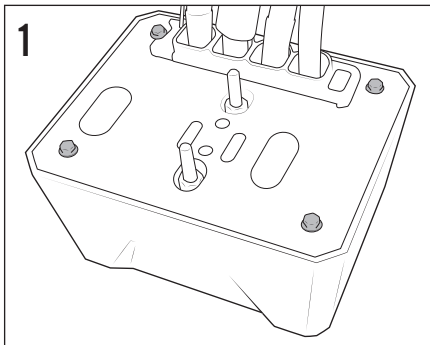

Figure 48

# APPENDIX A – WARN M12000 & M15000 INSTALLATION

Requires AEV M12000 or M15000 Winch Mounting Kit (PN: 10308016)

1. Remove the four screws attaching the winch solenoid cover then remove cover (fig. 1).
2. Remove the two nuts holding the solenoid pack to the mounting plate (fig. 2).
3. Slide the solenoid pack out far enough to access the hold down bolts.
4. Remove the bolts and replace them with the supplied M6 x 15 bolts (fig. 3).
5. Reassemble the solenoid pack.
6. Attach the new solenoid bracket as shown (fig. 4). DO NOT put the washers back on.
7. Install the solenoid bracket to the bumper with the supplied M6 x 20 bolts, nuts, and flat washers (fig. 5).



# APPENDIX B – POWER WAGON WINCH INSTALLATION

Requires Power Wagon Winch Mounting Kit (PN: 10305134AA)

## ROTATE THE GEAR HOUSING

1. Remove the Power Wagon winch mount bracket.
2. Remove the winch hook (if installed).
3. Unplug and remove the winch remote connector from the winch mount (fig. 1).
4. Remove the four (4) bolts holding the winch mount bracket to the winch and save the hardware.
5. Remove the P-clips holding the winch wiring to the winch (fig. 2).



Figure 1

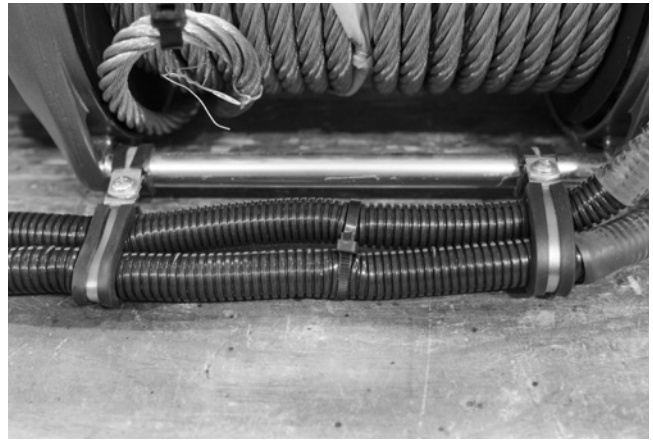

Figure 2

6. Disconnect the solenoid pack wiring from the winch motor (fig. 3).
7. Remove the winch solenoid pack from the winch by removing the two worm gear clamps (fig. 4).

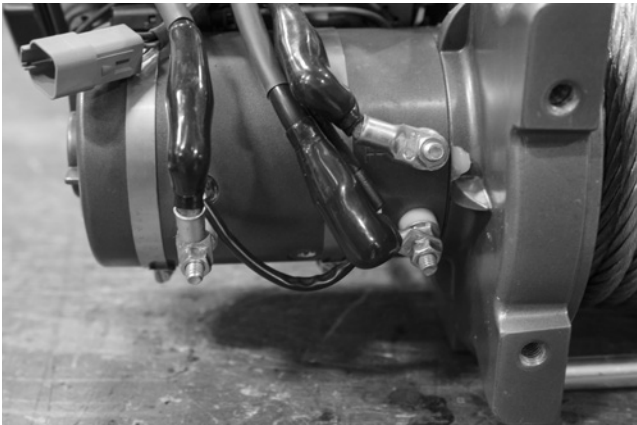

Figure 3

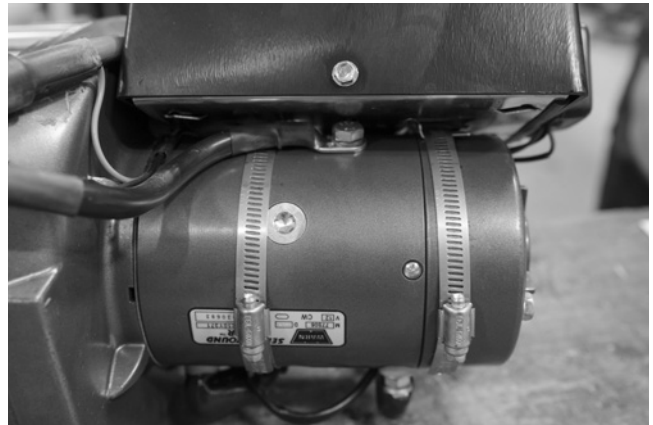

Figure 4

8. Place the winch upside down. This will be the new orientation in the bumper (fig. 5).
9. Remove the bolts holding the drum assembly and carefully remove the housing (fig. 6).

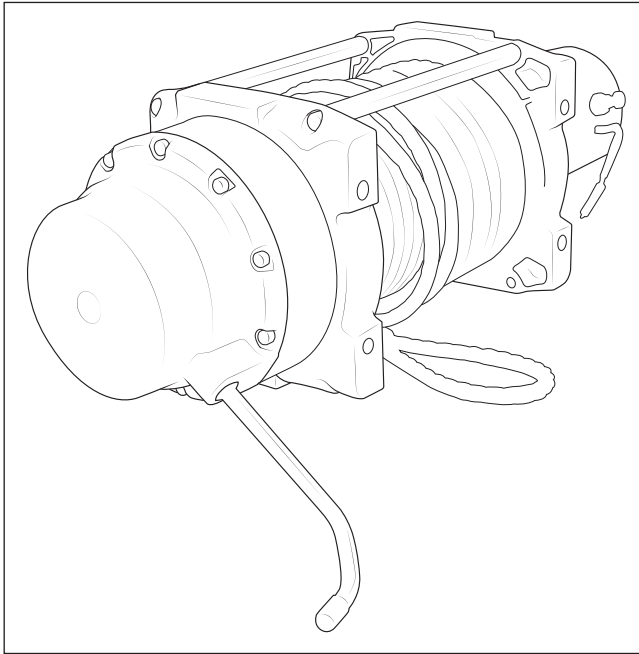

Figure 5

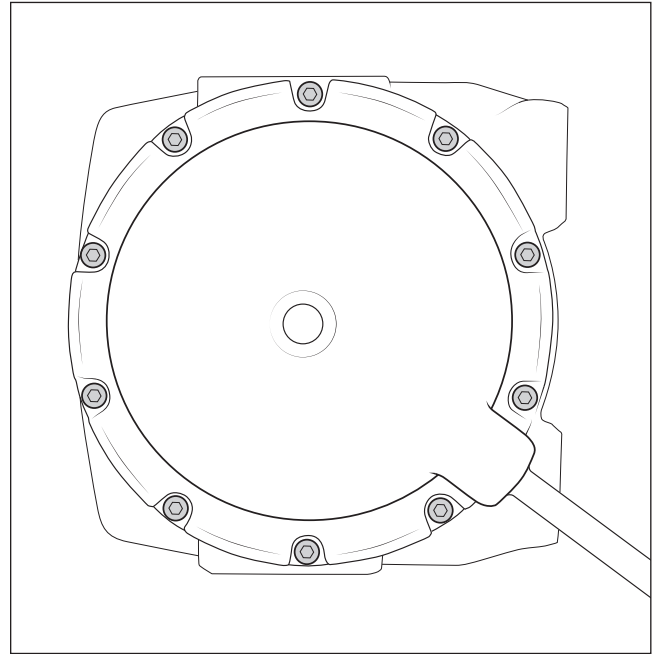

Figure 6

10. Separate both pieces of the planetary gear housing (fig. 7).
11. Place the planetary housing in the orientation shown (fig. 8). **Note: This will keep the detent ball and spring from falling out.**

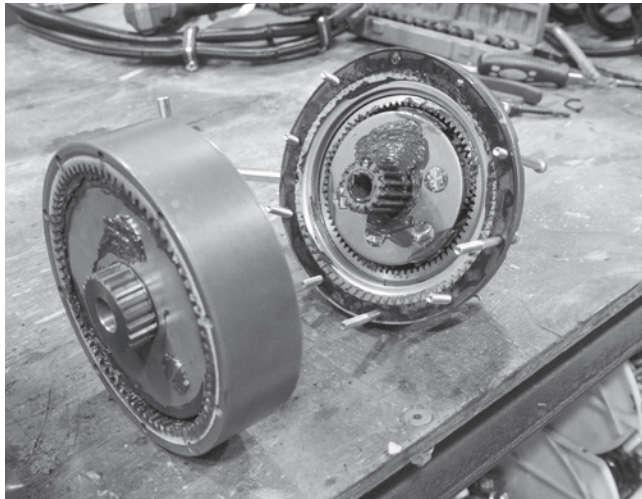

Figure 7

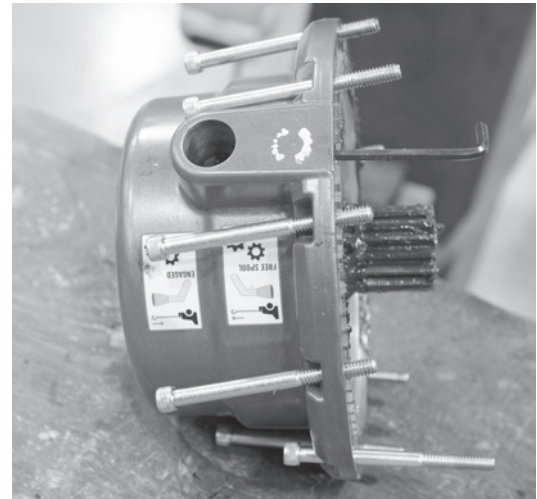

Figure 8

12. Remove the gasket to reveal the set screw that retains the engagement lever (fig. 9).
13. Using a 5/32" Hex Key, remove the set screw.
14. Remove the engagement lever. **NOTE: BE CAREFUL NOT TO LOSE THE DETENT BALL AND SPRING WHILE PULLING THE LEVER OUT.**
15. Remove the O-ring from the old engagement lever and install it on the new lever.
16. Install the new engagement lever into the housing. Refer to image for lever orientation (fig. 10).
17. Install the detent ball followed by the spring into the set screw hole—if removed—(fig. 10).
18. Install the set screw. **Note: Do not over tighten. Once the set screw is snug, check for proper lever movement and adjust as needed.**

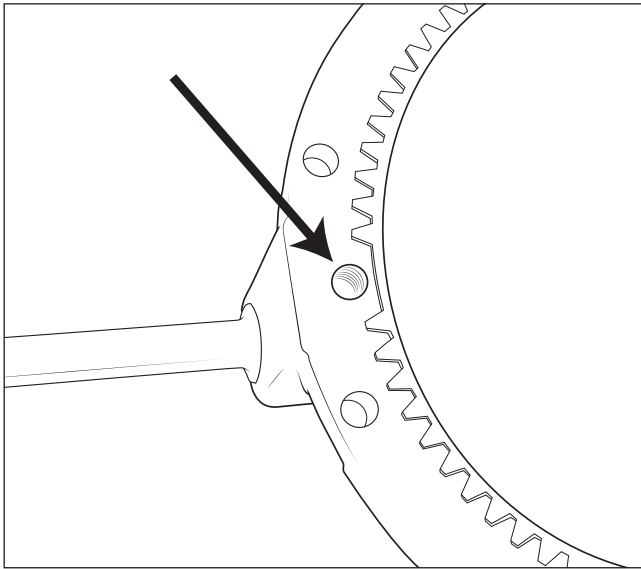

Figure 9

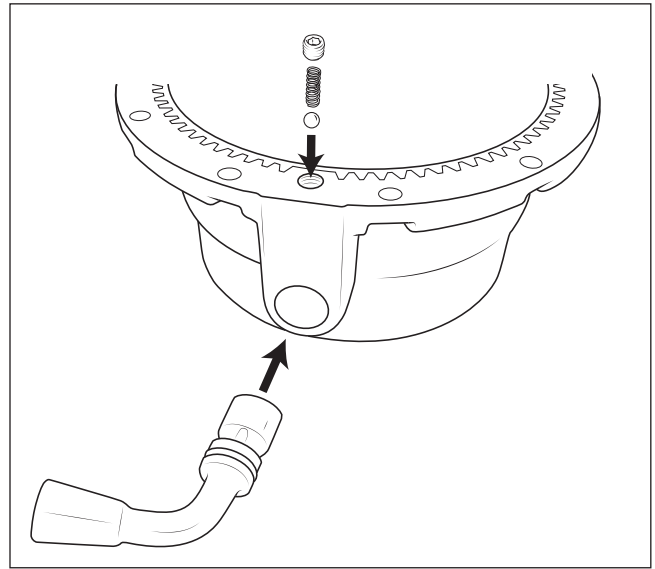
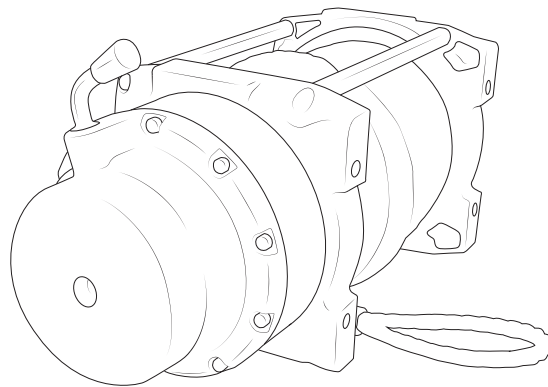

Figure 10

19. Set the engagement lever to the engaged position.
20. Use the new supplied gaskets and reassemble the housing in its new position. Install the motor rod into the drum assembly first, then install the drum assembly to the winch. **Note: Do not draw the bolts in to seat the drum. Make sure the drum fits with no gaps before tightening the bolts. Torque to 80 in-lbs.**



## ROTATE THE WINCH MOTOR

1. Remove the two (2) bolts holding the winch motor (fig. 11). **DO NOT SLIDE THE WINCH MOTOR BACK MORE THAN 3/8" OR THE BRUSHES WILL UNSEAT.**
2. Slide the winch motor back **NOT MORE THAN 3/8"** (fig. 12).

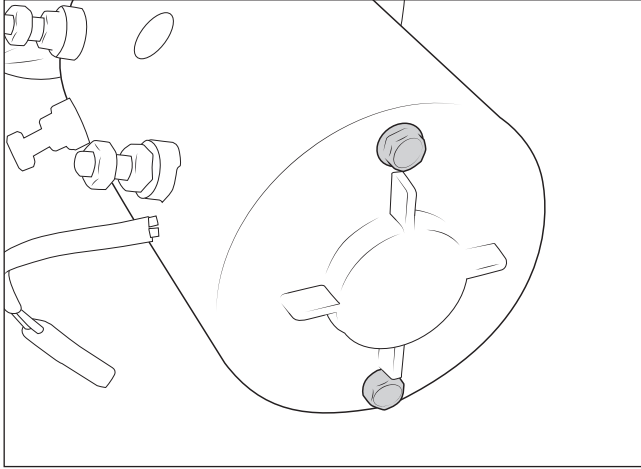

Figure 11

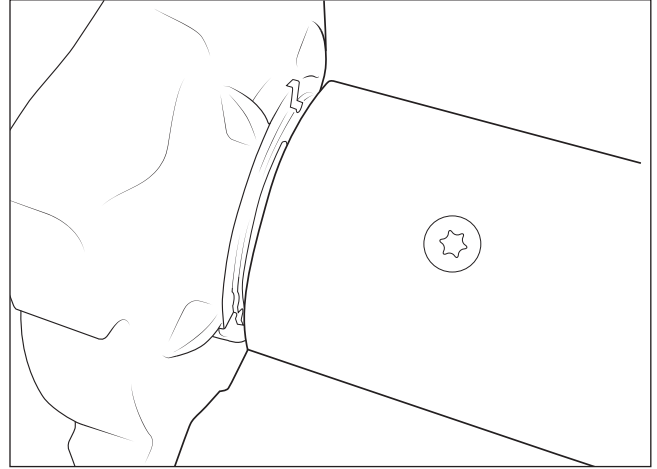

Figure 12

3. Clean the silicone out of the mating surface. Be careful not to tear the gasket (fig. 13).
4. Rotate the motor 180°, align the dowel pin with the hole, and slide it back forward (fig. 14).

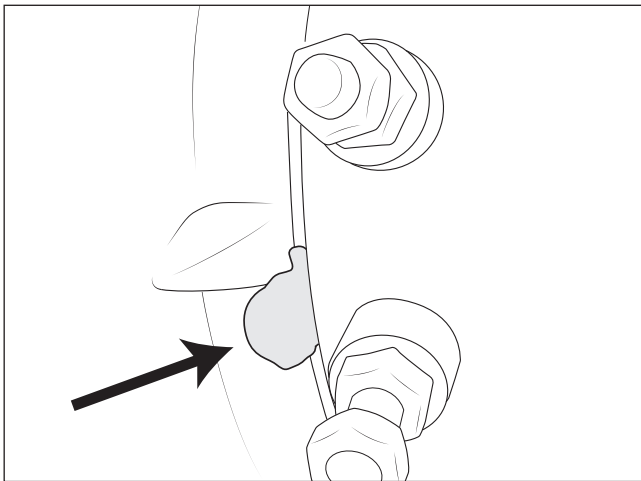

Figure 13

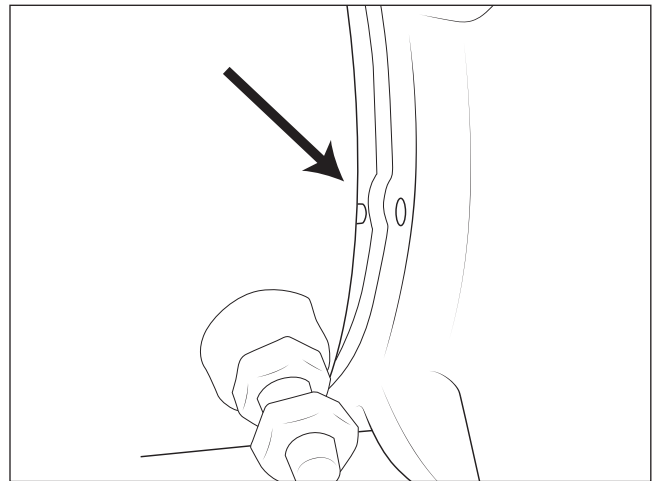

Figure 14

5. Re-install the bolts and tighten to 40 in-lbs.
6. Plug the upper two (2) slots where the winch motor meets the winch with silicone (fig. 15).

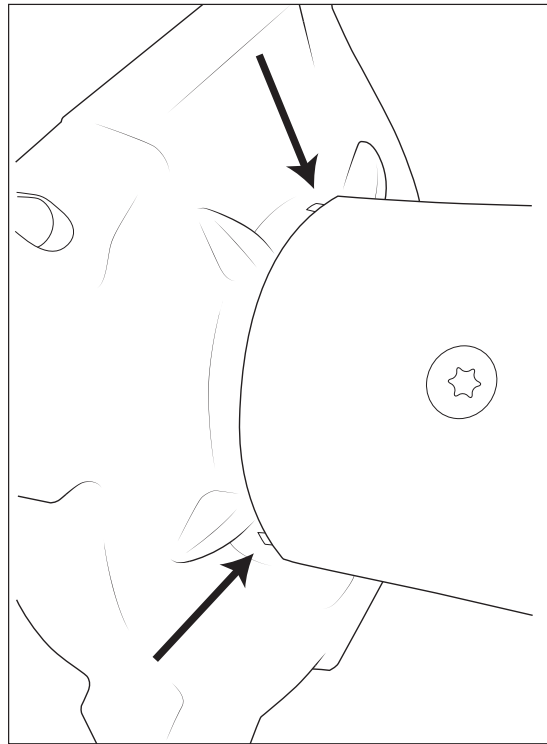

Figure 15

7. The instruction and warning labels on the winch will now be upside down. Remove these and replace with the supplied labels in the proper orientation (fig. 16).



Figure 16

## MODIFY THE SOLENOID PACK.

1. Remove the solenoid pack cover (fig. 17).
2. Remove the plastic rivets holding the small box to the side of the solenoid pack (fig. 18).

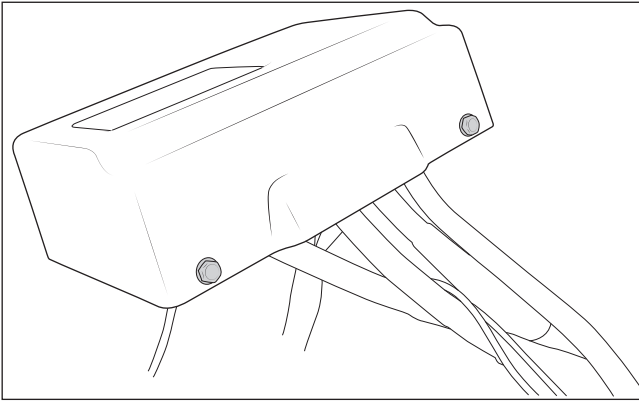

Figure 17

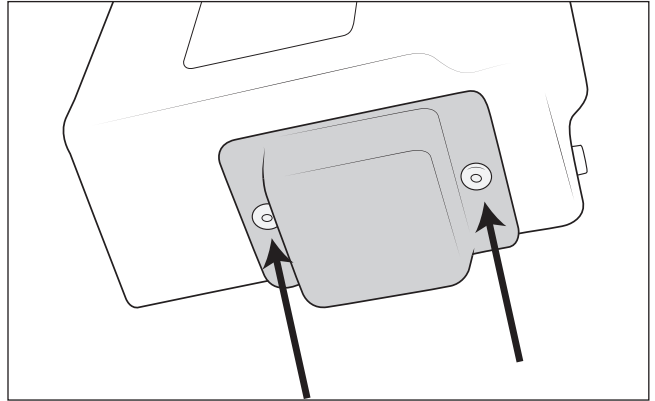

Figure 18

3. Bolt the solenoid pack to the new AEV bracket with the supplied m6 x 20 bolts, nuts, and washers. Install the bolts in the direction shown—through the bracket into the solenoid pack (fig. 19).
4. Insert the new m6 x 20 bolts and washers through the solenoid bracket, then re-install the solenoid pack cover (fig. 20).

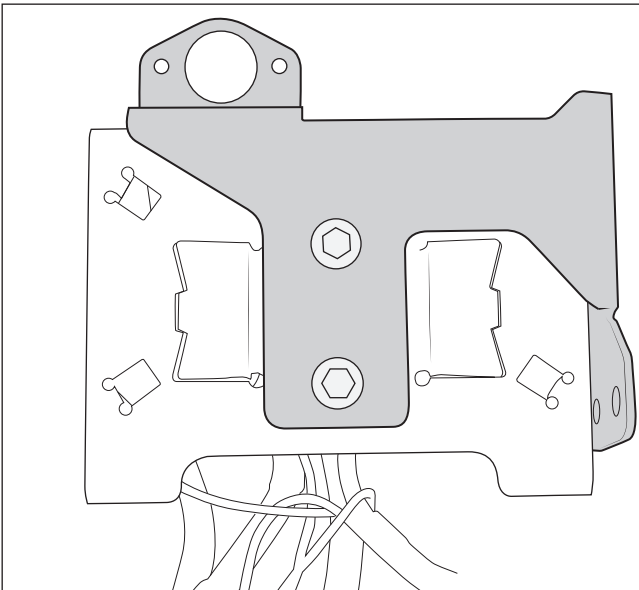

Figure 19

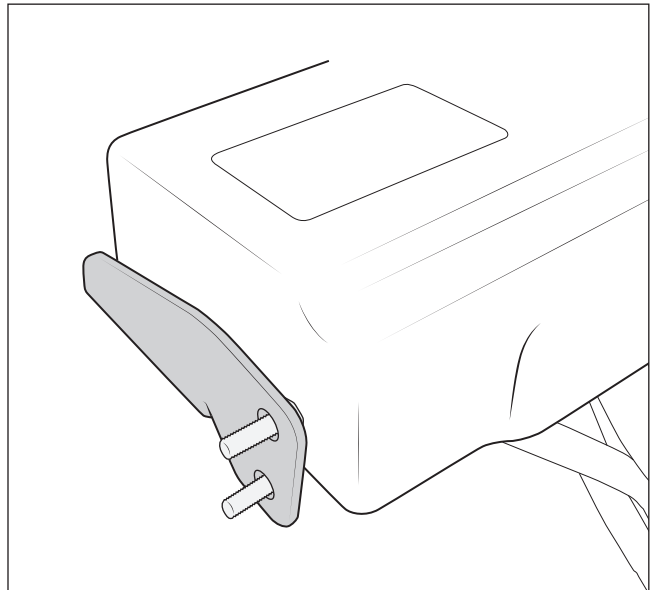

Figure 20

5. Attach the small box to the bottom of the solenoid pack with the supplied double sided adhesive. Be sure to clean and prep the surface with alcohol (fig. 21).
6. Install the winch remote plug into the AEV bracket with the supplied hardware and reconnect to the winch (fig. 22).

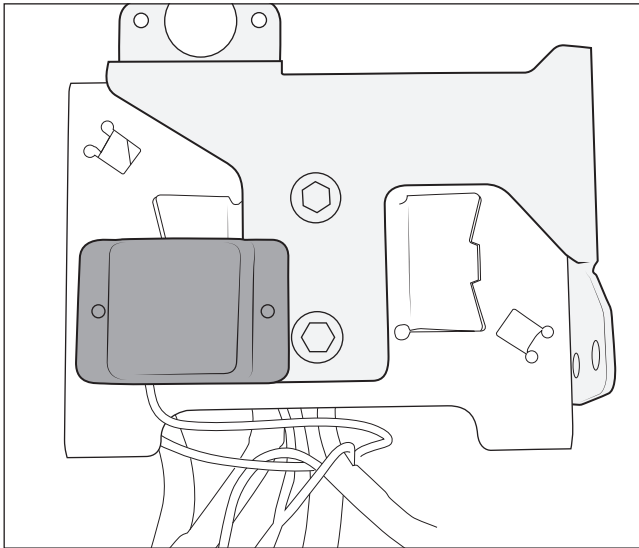

Figure 21

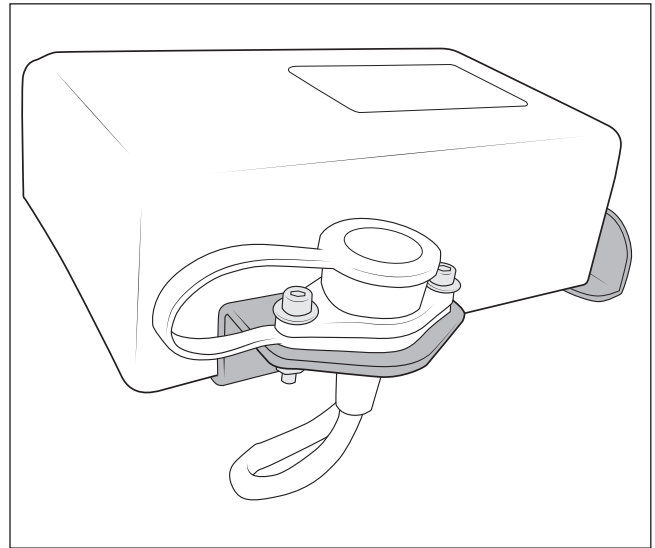

Figure 22

7. Lay the solenoid pack on the winch motor with the remote plug facing forward.
8. Re-attach the wiring to the winch. **NOTE: The winch wires and motor are labeled F1, F2, and A.**
9. Place the winch assembly into the bumper center section. Secure through the front using the factory hardware Note: You will need to remove the side rollers from the fairlead for access (fig. 23).
10. Attach the solenoid pack to the bumper using the supplied hardware (fig. 24). NOTE: You may need to adjust the solenoid pack on the bracket to fit between the winch and the bumper.

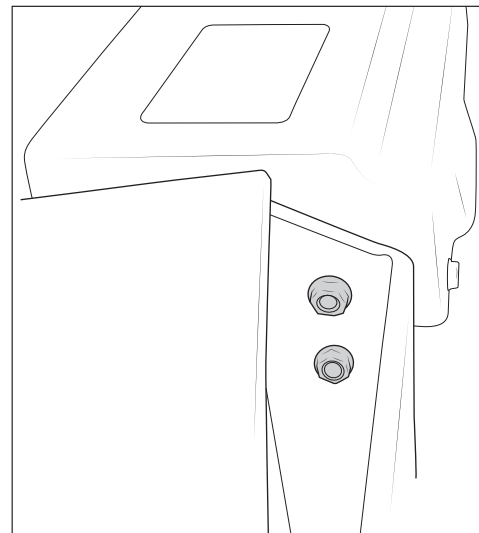

Figure 24

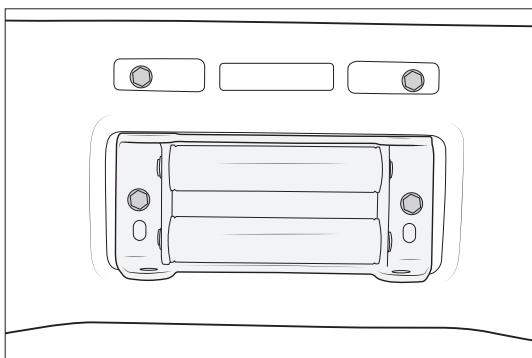

Figure 23